

MASTER[®]
CLIMATE SOLUTIONS

MCS Italy S.p.A.
Via Tione, 12 - 37010
Pastrengo (VR) - Italy
info@mcsitaly.it

MCS Central Europe Sp. z o.o
ul Magazynowa 5A,
62-023 Gądkki, Poland
office@mcs-ce.pl

MCS China LTD
Unit 11, No. 198, Changjian Rd.,
Shanghai, China
office@mcs-china.cn

4511.591 Edition 12 - Rev. 6

PROFESSIONAL HEATERS



UDHËZIMI I PËRDORIMIT	AL
НАРЪЧНИК ЗА ИЗПОЛЗВАНЕ И ПОДДРЪЖКА	BG
使用和维护手册	CN
PŘÍRUČKA PRO POUŽITÍ A ÚDRŽBU	CZ
BEDIENUNGS- UND WARTUNGSANLEITUNG	DE
VEJLEDNING OM BRUG OG VEDLIGEHOELSE	DK
KASUTUS- JA HOOLDUSJUHEND	EE
MANUAL DE INSTRUCCIONES PARA EL USO Y MANTENIMIENTO	ES
KÄYTTÖ- JA HUOLTO-OHJE	FI
MANUEL D'UTILISATION ET DE MAINTENANCE	FR
USER AND MAINTENANCE BOOK	GB
ΕΓΧΕΙΡΙΔΙΟ ΧΡΗΣΗΣ ΚΑΙ ΣΥΝΤΗΡΗΣΗΣ	GR
KNJIŽICA O UPORABI I ODRŽAVANJU	HR
HASZNÁLATI ÉS KARBANTARTÁSI KÉZIKÖNYV	HU
LIBRETTO USO E MANUTENZIONE	IT
NAUDOJIMO IR PRIEŽIŪROS KNYGELE	LT
LIETOŠANAS UN TEHNISKĀS APKOPES GRĀMATINA	LV
HANDLEIDING VOOR GEBRUIK EN ONDERHOUD	NL
HEFTE FOR BRUK OG VEDLIKEHOLD	NO
INSTRUKCJA OBSŁUGI I KONSERWACJI	PL
MANUAL DE USO E MANUTENÇÃO	PT
LIVRET DE UTILIZARE SI ÎNTREȚINERE	RO
РУКОВОДСТВО ПО ЭКСПЛУАТАЦИИ И ТЕХНИЧЕСКОМУ ОБСЛУЖИВАНИЮ	RU
ANVÄNDAR- OCH UNDERHÅLLSHANDBOK	SE
PRIROČNIK Z NAVODILI ZA UPORABO IN VZDRŽEVANJE	SI
PRÍRUČKA PRE POUŽITIE A ÚDRŽBU	SK
KULLANIM VE BAKIM KİTAPÇIĞI	TR
ІНСТРУКЦІЯ З ОБСЛУГОВУВАННЯ	UA
INSTRUKCIJA KORIŠCENJA	YU

B 2 EPB | B 3 EPB | B 3,3 EPB | B 5 EPB | B 9 EPB | B 15 EPB | B 22 EPB

TË DHENAT TEKNIKE - ТЕХНИЧЕСКИ ДАНИ - 技术参数 - TECHNICKÉ ÚDAJE - TECHNISCHE DATEN - TEKNISK DATA - TEHNILISED ANDMED - ESPECIFICACIONES TÉCNICAS - TEKNISET TIEDOT - DONNÉES TECHNIQUES - TECHNICAL DATA - TEHNIKA EOMENA - TEHNIČKI PODACI - MŐSZAKI ADATOK - DATI TECNICI - TECHNINIAI DUOMENYS - TEHNISKIE DATI - TECHNISCHE GEGEVENS - TEKNISKE DATA - DANE TECHNICZNE - DADOS TÉCNICOS - INFORMAZIONI TEHNICE - ТЕХНИЧЕСКИЕ ДАННЫЕ - TEKNISKA DATA - TEHNIČNI PODATKI - TECHNICKÉ PARAMETRE - TEKNİK ÖZELLİKLER - ТЕХНІЧНІ ДАНИ - TEHNIČKI PODACI

Model		B2 EPB	B3 EPB	B3,3 EPB	B5 EPB	B9 EPB	B15 EPB	B22 EPB
Power	kW	1 - 2	1,5 - 3,0	1,65 - 3,3	2,5 - 5	4,5 - 9	7 - 15	11 - 22
	kcal/h	860 - 1720	1250 - 2500	1433 - 2866	2150 - 4300	3870 - 7740	6450 - 12900	9460 - 18920
Switch Position 1	kW	OFF	OFF	OFF	OFF	OFF	OFF	OFF
Switch Position 2	kW	Fan	Fan	Fan	Fan	Fan	Fan	Fan
Switch Position 3	kW	1	1,5	1,65	2,5	4,5	7,5	11
Switch Position 4	kW	2	3	3,30	5	9	15	22
Max current cons.	A	8,7	13	14,5	7,2	13	22	32
Voltage	V/Hz	230/50	230/50	230/50	400/50	400/50	400/50	400/50
Air displacement	m³/h	184	510	510	510	800	1700	2400
Temperature range	°C	5-35	5-35	5-35	5-35	5-35	5-35	5-35
Weight	kg	3,7	5,1	5,1	6,4	9	15	20
Dimension L x W x H	cm	22x20x33	26x26x41	26x26x41	29x35x38	32x41x42	34x47x49	35x54x59
Resistance norm		IPX4	IPX4	IPX4	IPX4	IPX4	IPX4	IPX4

FIGURAT - РИСУНКА - 图纸 - OBRÁZKY - ABBILDUNGEN - TEGNINGER - JOONISED - IMÁGENES - KUVAT - DESSINS - PICTURES - ΣΧΕΙΑ - CRTEŽE - RAJZOK - FIGURE - PIEŠINIAI - ZİMËJUMI - TEKENINGEN - REGNINGER - RYSUNKI - DESENHOS - DESENE TEHNICE - РИСУНКИ - TECKNINGAR - RISBE - OBRÁZKY - RESIMLER - РИСУНКИ - CRTEŽE

Front B 2 / 3 / 3,3 EPB

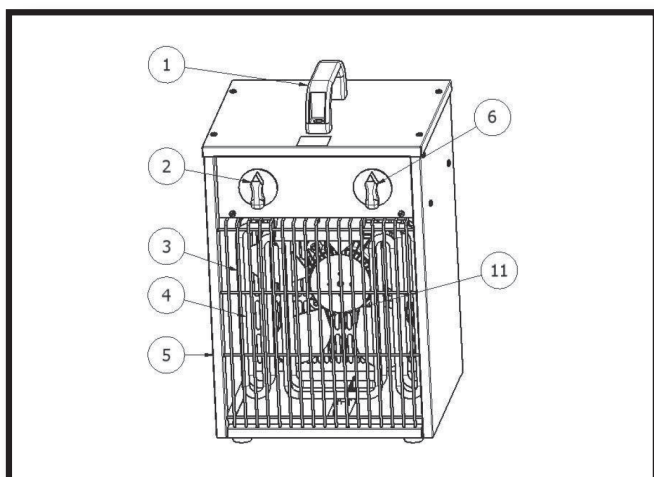

Fig. 1

Back B 2 / 3 / 3,3 EPB

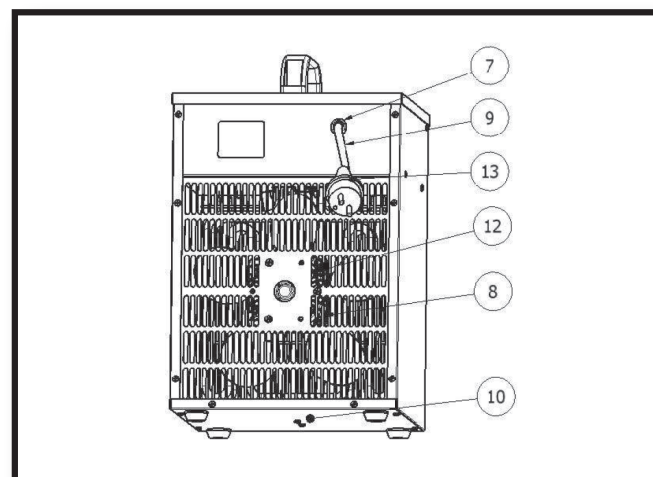

Fig. 1

AL

BG

CN

CZ

DE

DK

EE

ES

FI

FR

GB

GR

HR

HU

IT

LT

LV

NL

NO

PL

PT

RO

RU

SE

SI

SK

TR

UA

YU

AL

BG

CN

CZ

DE

DK

EE

ES

FI

FR

GB

GR

HR

HU

IT

LT

LV

NL

NO

PL

PT

RO

RU

SE

SI

SK

TR

UA

YU

B 2 / 3 / 3,3 / 5 / 9 / 15 / 22 EPB

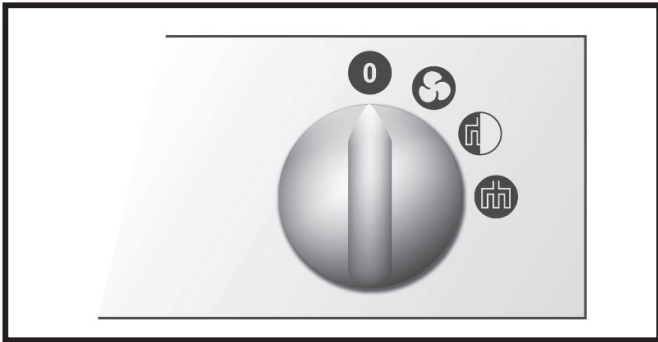

Fig. 4

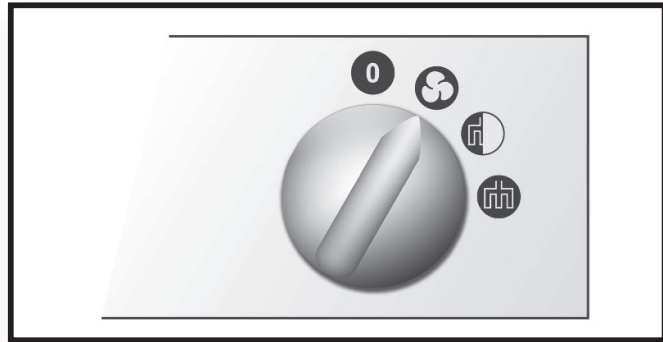

Fig. 5

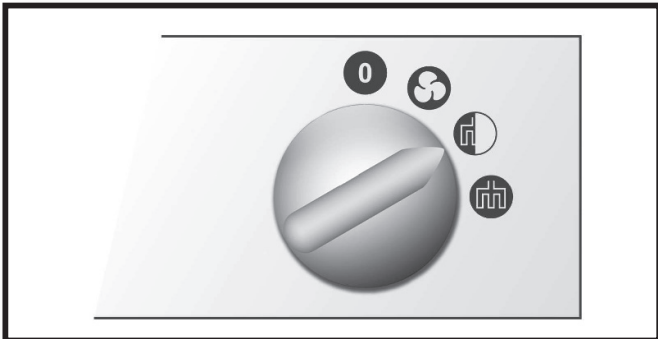

Fig. 6

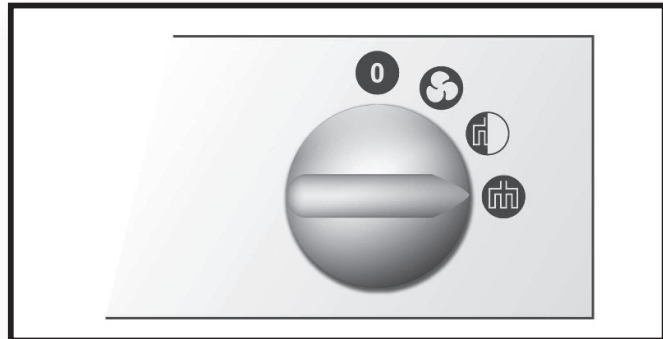

Fig. 7

B 2 EPB

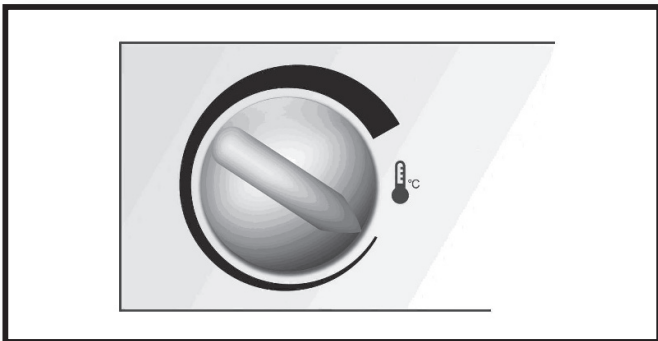

Fig. 8

B 3 / 3,3 / 5 / 15 / 22 EPB

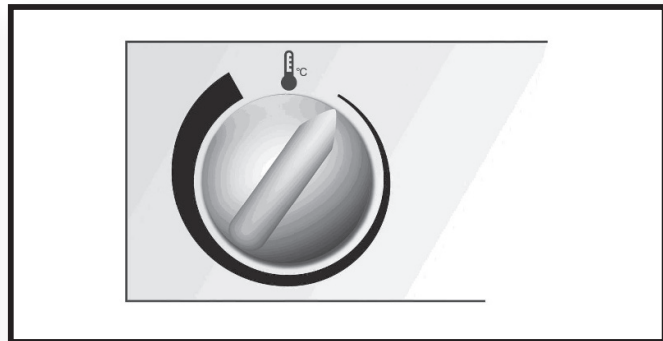

Fig. 8

B 9 EPB

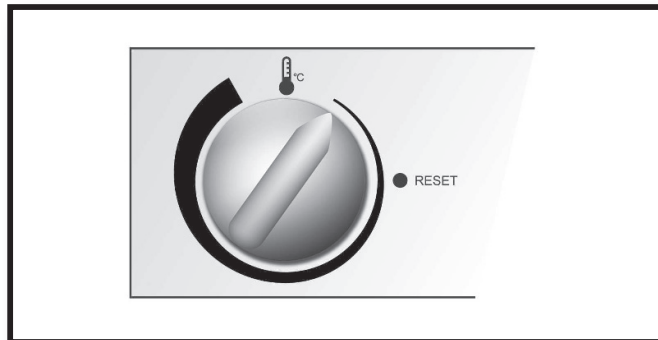

Fig. 8

PARAGRAPH SUMMARY

1...	SAFETY INSTRUCTIONS
2...	UNPACKING AND TRANSPORT
3...	DESCRIPTION OF INDIVIDUAL COMPONENTS
4...	SWITCHING ON
5...	SWITCHING OFF
6...	TEMPERATURE CONTROL
7...	THERMAL CIRCUIT BREAKER "RESET" (9 EPB)
8...	OUT-OF-SEASON STORAGE
9...	FUNCTIONAL INSPECTION
10...	TROUBLESHOOTING

IMPORTANT!!! Carefully read this service manual before you start to use, repair or clean the heater. Improper use of the appliance may cause serious injuries, burns, electric shock or fire.

GB

►► 1. SAFETY INSTRUCTIONS

The appliance has been designed for heating closed areas such as e.g. warehouses, shops and houses. It complies with the Directive No. 2006/95/EC, 2004/108/EC including the harmonised standards No. EN 60335-1 and EN 60335-2.

⚠ WARNING! Do not place the heater directly under the wall outlet. Do not touch internal components of the heater.

This appliance is not intended for use by persons (including children) with reduced physical, sensory or mental capabilities, or lack of experience and knowledge, unless they have been given supervision or instruction concerning use of the appliance by a person responsible for their safety. Children should be supervised to ensure that they do not play with the appliance.



- Do not cover the heater when it is operating. The appliance may get overheated.
- Do not operate the appliance close to humid places such as water tanks, bathtubs, showers or swimming pools. Any contact with water may be the reason of short-circuit or electric shock.
- The heater should be kept at a safe distance from flammable materials. The minimum safety distance should not be inferior to 0.5 m, otherwise you run the risk of starting the fire.
- Do not use the heater in dusty spaces or rooms where gasoline, solvents, paints or other volatile and inflammable materials are stored in order to avoid

the risk of explosion.

- The heater should not be used close to the curtains or other textiles in order to avoid the risk of fire.
- Be particularly cautious when using the heater in the rooms frequented by children or animals.
- The heater should be supplied from a source meeting the requirements specified on the rating plate.
- Use only a feeder cable including the earth lead in order to avoid electric shock in emergency situations.
- Do not unplug the heater by pulling the wire out of the wall socket. The appliance should cool down through the ventilation effect.
- Unplug the heater when not used in order to avoid accidental damages.
- Before you dismantle the casing check if the feeder cable has been pulled out of the wall socket. Internal components may be live.

►► 2. UNPACKING AND TRANSPORT

- Open the package and take the heater out including all the safety locks installed for the period of transport.
- Should the appliance seem damaged, notify immediately the seller of the same.
- Transport the heater using the lifting eyes No. 1 shown in Figs. 1, 2 and 3, page 2.
- The heater should be transported in original package including the safety locks.

►► 3. DESCRIPTION OF INDIVIDUAL COMPONENTS

See Figs. 1-2-3, Page. 2.

- 1) Lifting eye
- 2) Thermostat

- 3) Front protective grid
- 4) Heating element
- 5) Casing
- 6) Switch
- 7) Cable penetration
- 8) Back protective grid
- 9) Power supply cable
- 10) Base foot
- 11) Fan
- 12) Motor
- 13) Plug

▶▶ 4. SWITCHING ON

⚠ WARNING !!!: Carefully read this service manual before you start to use the heater. The instructions contained herein will allow you to use the appliance in a safe manner.

Make sure the power supply cable has not been damaged. If the supply cord is damaged, it must be replaced by the manufacturer, its service agent or similarly qualified persons in order to avoid a hazard. Moreover, check if the technical parameters of power supply source comply with the requirements specified on the rating plate. Place the appliance in its upright position. Make sure the switch is in its "0" position shown in Fig. 4. Connect the heater to the power supply source. Turn the switch and leave it for 5 seconds in the positions as follows:

- ▶ Fan only: Fig. 5;
- ▶ 1st degree of heating: Fig. 6, and
- ▶ 2nd degree of heating: Fig. 7.

▶▶ 5. SWITCHING OFF

Turn the switch to its "0" position. Once the heating is off, leave the fan operating for 3 minutes.

▶▶ 6. TEMPERATURE CONTROL

The temperature in the room may be set by means of the control knob (Fig. 8, page 2). Once the pre-set temperature is produced, the thermostat will automatically switch the heating elements off while the

fan will continue to operate thus protecting the appliance from overheating. If the temperature falls down beyond the pre-set value, the system will switch the heating elements on again.

▶▶ 7. THERMAL CIRCUIT BREAKER "RESET" (9 EPB)

The appliance has been equipped with an integrated thermal circuit breaker ensuring high safety level. The breaker will automatically switch the power supply off once a limit temperature is exceeded. Should it happen, let the appliance cool down and only then, look for the reason of the problem. Next push the "RESET" button (Fig. 8) with a pointed tip in order to unlock the thermal circuit breaker. If the heater does not operate, contact the seller or approved service centre.

▶▶ 8. OUT-OF-SEASON STORAGE

Should the appliance remain idle for a long period of time, clean it before shoving by blowing the inside with compressed air. The heater should be kept in a dry and clean place. Before you start using it again make sure the power supply cable has not been damaged. In the case of any doubts contact the seller or approved service centre.

GB

▶▶ 9. FUNCTIONAL INSPECTION

The appliance should be checked at least once a year by competent service personnel approved by the manufacturer. Any inspections or repairs should be conducted by competent personnel only.

▶▶ 10. TROUBLESHOOTING

PROBLEM	REASON	SOLUTION
The motor operates while the appliance does not heat.	Thermal circuit breaker is active. Thermostat has been damaged. Relay has been damaged. Heating element has been damaged.	Let the heater cool down and push the "RESET" button . Replace the thermostat. Replace the relay (400 V models). Replace the heating element.
The motor does not operate while the heating elements are hot.	Motor has been damaged. Fan has been stopped. Switch has been damaged.	Replace the motor. Unlock / clean the fan. Replace the switch.
The whole appliance does not operate.	Electric circuit open. Switch has been damaged.	Check power supply connection. Replace the switch.
Reduced air flow.	Foul air duct. Motor has been damaged.	Open the air duct. Replace the motor.

AL

BG

CN

CZ

DE

DK

EE

ES

FI

FR

GB

GR

HR

HU

IT

LT

LV

NL

NO

PL

PT

RO

RU

SE

SI

SK

TR

UA

YU

SKEMA ELEKTRIKE - ЕЛЕКТРИЧЕСКА СХЕМА - 电路图 - ELEKTRICKÉ SCHÉMA - ELEKTRISCHES SCHALTBILD - EL-DIAGRAM - ELEKTRISKEEM - ESQUEMA ELÉCTRICO - KYTKENTÄKAAVIO - SCHÉMA DE CÂBLAGE - WIRING DIAGRAM - ΣΧΕΙΑΓΡΑΜΜΑ ΤΟΥ ΗΛΕΚΤΡΙΚΟΥ ΚΥΚΛΩΜΑΤΟΣ - SHEMA ELEKTRIKE - ELEKTROMOS KAPCSOLÁSI SÉMA - SCHEMA ELETTRICO - ELEKTRINE SCHEMA - ELEKTRISKĀ SHĒMA - SCHAKELSCHEMA - ELEKTRISK SKJEMA - SCHEMAT ELEKTRYCZNY - ESQUEMA ELÉCTRICO - SCHEMĂ ELECTRICĂ - ЭЛЕКТРИЧЕСКАЯ СХЕМА - ELANLÄGGNING - ELEKTRIČNA SHEMA - ELEKTRICKÁ SCHÉMA - ELEKTRĐK SEMASI - ЕЛЕКТРИЧНА СХЕМА - SHEMA ELEKTRIKE

W – switch
M – motor
WR – temperature limiter
WZ – overheat sensor

T – thermostat
PK – relay
L – coil
R1,R2,R3,R4,R5,R6 – heating elements

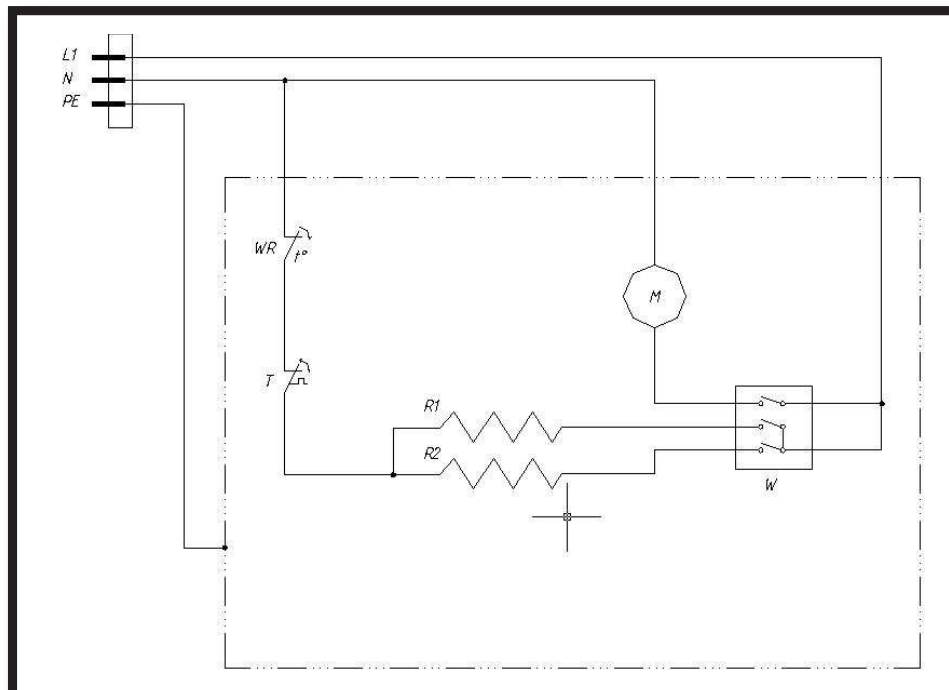

2 kW

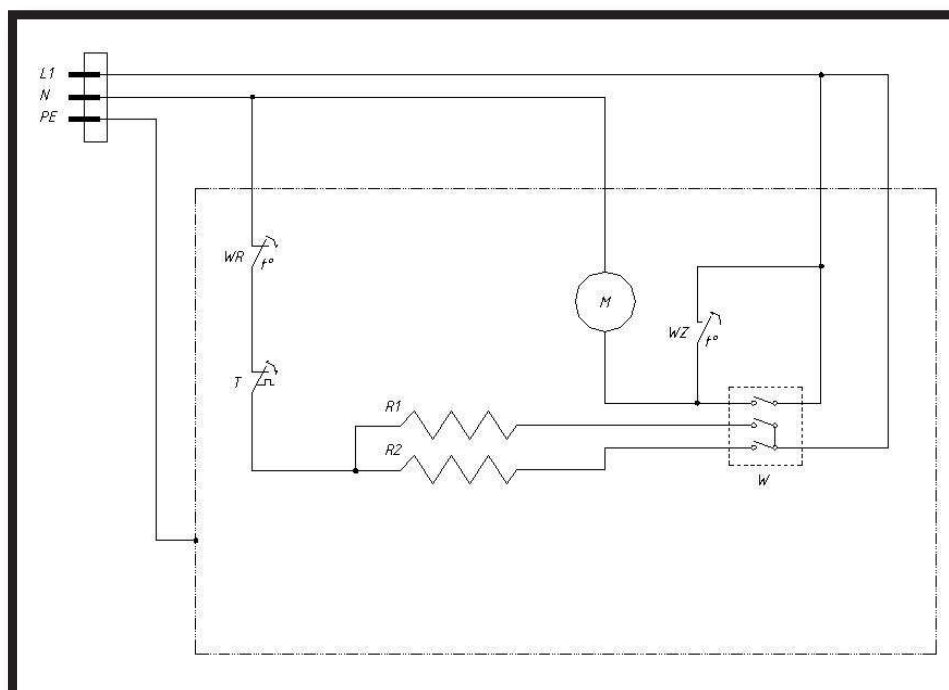

3 / 3,3 kW