

# Ersatzteile

Spare parts  
Spares  
Pièces de rechange  
Piezas de recambio  
Ricambi  
Peças de reposição  
Pieșe de schimb  
Náhradných dielov  
Reserve dele  
Części zamienne



## CF 2 , CF 2i

0100211 - 0100218

Ab Serien-Nr.



**Weber Maschinenteknik GmbH**

Im Boden 5 – 8 , 10

D- 57334 Bad Laasphe - Rückershausen / Germany

Tel.: +49 (0) 2754 / 398 0

Fax: +49 (0)2754 / 398 101

E-Mail: [info@webermt.de](mailto:info@webermt.de)

[www.webermt.de](http://www.webermt.de)



BITTE, NOTIEREN SIE SERIENNUMMER UND MOTORNUMMER IHRER MASCHINE:

PLEASE WRITE DOWN SERIALNUMBERS OF MACHINE AND ENGINE:

NOTEZ SVP LE NUMERO DE SERIE ET LE NUMERO DU MOTEUR DE VOTRE MACHINE:

SI PREGA DI ANNOTARE SEMPRE I NUMERI DI SERIE SIA DELLA VS. MACCHINA CHE DEL MOTORE:

MAQUINA: ROGAMOS ANOTEN EL NUMERO DE SERIE Y NUMERO DE MOTOR DE SU MAQUINA:

PROSIMY ZANOTOWAĆ NUMER MASZYNY I SILNIKA

MASCHINE  
MACHINE  
MACCHINA  
MAQUINA  
MASZYNA



MOTOR  
ENGINE  
MOTEUR  
MOTORE  
SILNIK



ZUR VERMEIDUNG VON FEHLLIEFERUNGEN UND VERZÖGERUNGEN SIND BEI DER BESTELLUNG VON ERSATZTEILEN FOLGENDE ANGABEN UNBEDINGT ERFORDERLICH:

- MASCHINENTYP
- SERIENNUMMER DER MASCHINE
- SERIENNUMMER DES MOTORS (BEI MOTORTEILEN)
- TEILENUMMER
- BESTELLMENGE

TO AVOID ERRORS IN DELIVERY PLEASE STATE THESE PARTICULARS WHEN ORDERING:

- TYPE OF MACHINE
- SERIAL NO. OF MACHINE
- SERIAL NO. OF ENGINE (ON ENGINE PARTS)
- PART-NO.
- QUANTITY REQUIRED

AFIN D'EVITER DES ERREURS DE COMMANDE ET DES RETARDS DE LIVRAISON IL EST NECESSAIRE D'INDIQUER LES CARACTERISTIQUES SUIVANTES:

- TYPE DE MACHINE
- LE NUMERO DE SERIE DE LA MACHINE
- LE NUMERO DE SERIE DU MOTEUR
- LE NUMERO D'IDENTITE DE LA PIECE
- LA QUANTITE SOUHAITEE

ONDE EVITARE DISGUIDI E RITARDI NELLE CONSEGNE DIE RICAMBI SI PREGA DI INDICARE SEMPRE:

- TIPO DELLA MACCHINA
- NUMERO DI SERIE DELLA MACCHINA
- NUMERO DI SERIE DEL MOTORE (SE SI RICHIEDONO PEZZI DEL MOTORE)
- NUMERO D'ORDINE DIE SINGOLI RICAMBI
- QUANTITA

A FI DE EVITAR ERRORES DE ENTREGA, ROGAMOS INDIQUEN LOS SIGUIENTES DATOS CUANDO PASE PEDIDOS DE RECAMBIOS:

- MODELO DE MAQUINA
- NO. DE SERIE DE LA MAQUINA
- NO. DE SERIE DEL MOTOR (EN PIEZAS PARA MOTOR)
- REFERENCIA DEL RECAMBIO
- CANTIDAD PEDIDA

PROSIMY O PODANIE NASTĘPUJĄCYCH DANYCH PRZY SKŁADANIU ZAMÓWIENIA.

- TYP MASZYNY
- NUMER SERYJNY MASZYNY
- NUMER SERYJNY SILNIKA (PRZY CZĘŚCIACH DO SILNIKA)
- NUMER CZĘŚCI ZAMIEWNNEJ
- ZAMAWIANA ILOŚĆ

## E 3585-0115

Position Ref.No. Repère Posizione Posicion	Menge Quantity Quantité Quantita Cantidad	Teile-Nr. Part-No. No. Référence Nr. d'Ordine No. Referenzia	Hinweis Hints Indications Indicazione Indicaciones	Position Ref. No. Repère Posizione Posicion	Menge Quantity Quantité Quantita Cantidad	Teile-Nr. Part-No. No. Référence Nr. d'Ordine No. Referenzia	Hinweis Hints Indications Indicazione Indicaciones
1	1	11001508					
2	4	21000579					
3	4	11000985					
4	4	20029022	SKB 10				
5	4	25031004	DIN934-M10				
6	1	25030002	DIN908-M14x1,5				
7	2	25038018	DIN933-M12x20				
8	2	20029032	SKM 12				
9	1	10005404					
10	1	20013008					
11	4	25044004	DIN912-M8x16-10.9				
12	4	20029011	VSKZ 8				
13	1	11000756					
14	1	20013090					
15	1	11001799					
16	2	25038008	DIN933-M8x25				
17	2	20029024	Nord-Lock 8,0				
18	1	11000757					
19	2	25001127					
20	1	11000759					
21	2	25044104	DIN912-M12x40				
22	2	20029026	Nord-Lock 12,0				
23	1	25017007					
24	1	11000758					
25	1	10016071					
26	1	10007370					
27	1	20029001	VSK 10				
28	1	21000641	DIN7991-M8x25-ISR				
29	1	25005003	DIN6798-V8,4				

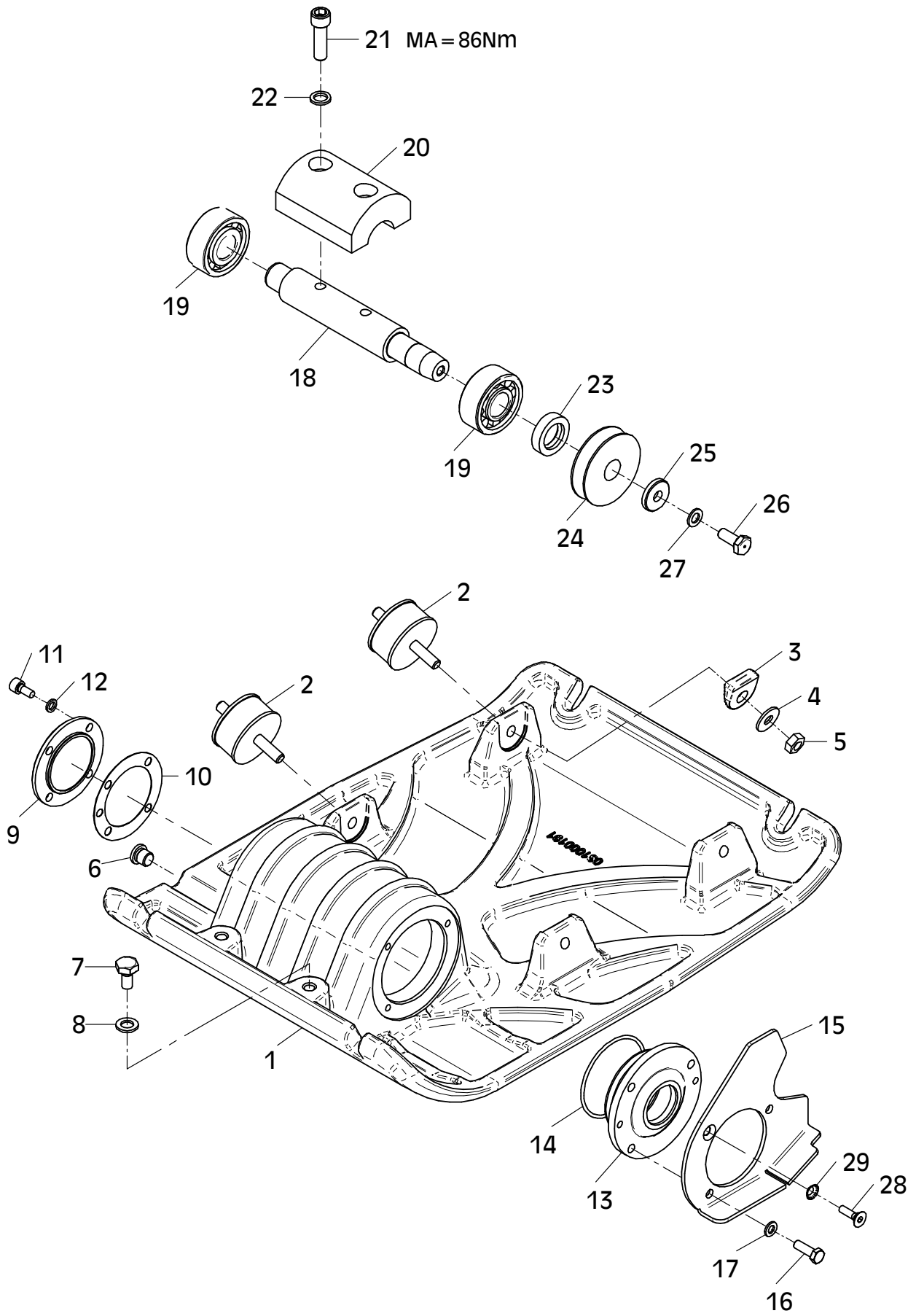

E 3585-0115

## E 3586-0115

Position Ref.No. Repère Posizione Posicion	Menge Quantity Quantité Quantita Cantidad	Teile-Nr. Part-No. No. Référence Nr. d'Ordine No. Referenzia	Hinweis Hints Indications Indicazione Indicaciones	Position Ref. No. Repère Posizione Posicion	Menge Quantity Quantité Quantita Cantidad	Teile-Nr. Part-No. No. Référence Nr. d'Ordine No. Referenzia	Hinweis Hints Indications Indicazione Indicaciones
1	1	11001714					
2	4	25049020	DIN7349-10,5				
3	4	20029001	VSK 10				
4	4	25031004	DIN934-M10				
5	1	11001800					
6	6	25038015	DIN933-M10x30				
7	6	25048003	DIN125-A10,5				
8	6	20029033	SKM 10				
9	6	25031004					
10	1	20026465					
11	2	25025191	DIN80705-M20x1,5				
12	2	20005021					
13	2	20022002	Tensilock M8				

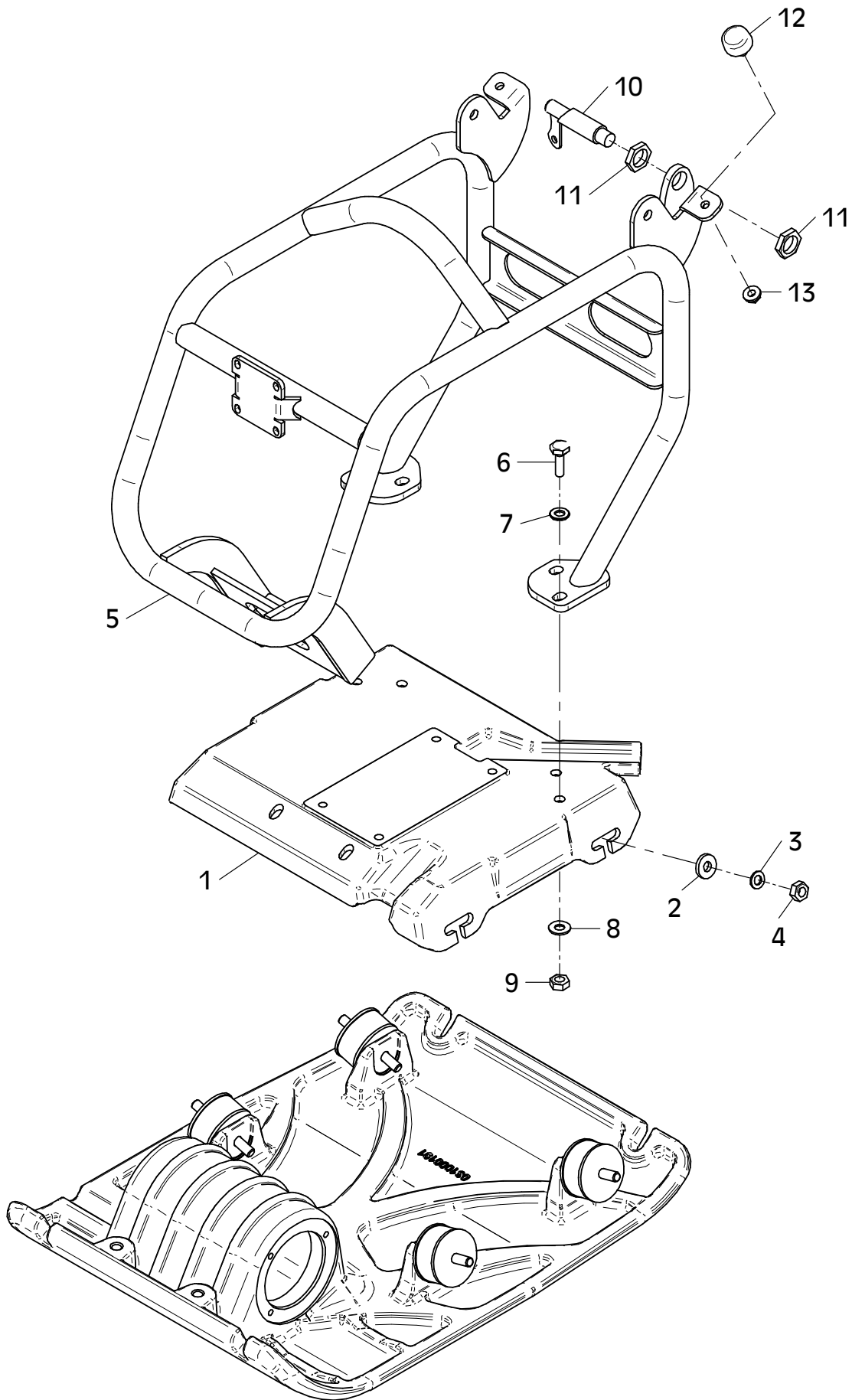

E 3586-0115

## E 3590-0115

Position Ref.No. Repère Posizione Posicion	Menge Quantity Quantité Quantita Cantidad	Teile-Nr. Part-No. No. Référence Nr. d'Ordine No. Referenzia	Hinweis Hints Indications Indicazione Indicaciones	Position Ref. No. Repère Posizione Posicion	Menge Quantity Quantité Quantita Cantidad	Teile-Nr. Part-No. No. Référence Nr. d'Ordine No. Referenzia	Hinweis Hints Indications Indicazione Indicaciones
1	1	11001715					
2	4	25049020	DIN7349-10,5				
3	4	20029001	VSK 10				
4	4	25031004	DIN934-M10				
5	1	11001805					
6	4	25038015	DIN933-M10x30				
7	4	25048003	DIN125-A10,5				
8	4	20029033	SKM 10				
9	4	25031004					
10	1	20026465					
11	2	25025191	DIN80705-M20x1,5				
12	2	20005013					
13	2	20022002	Tensilock M8				



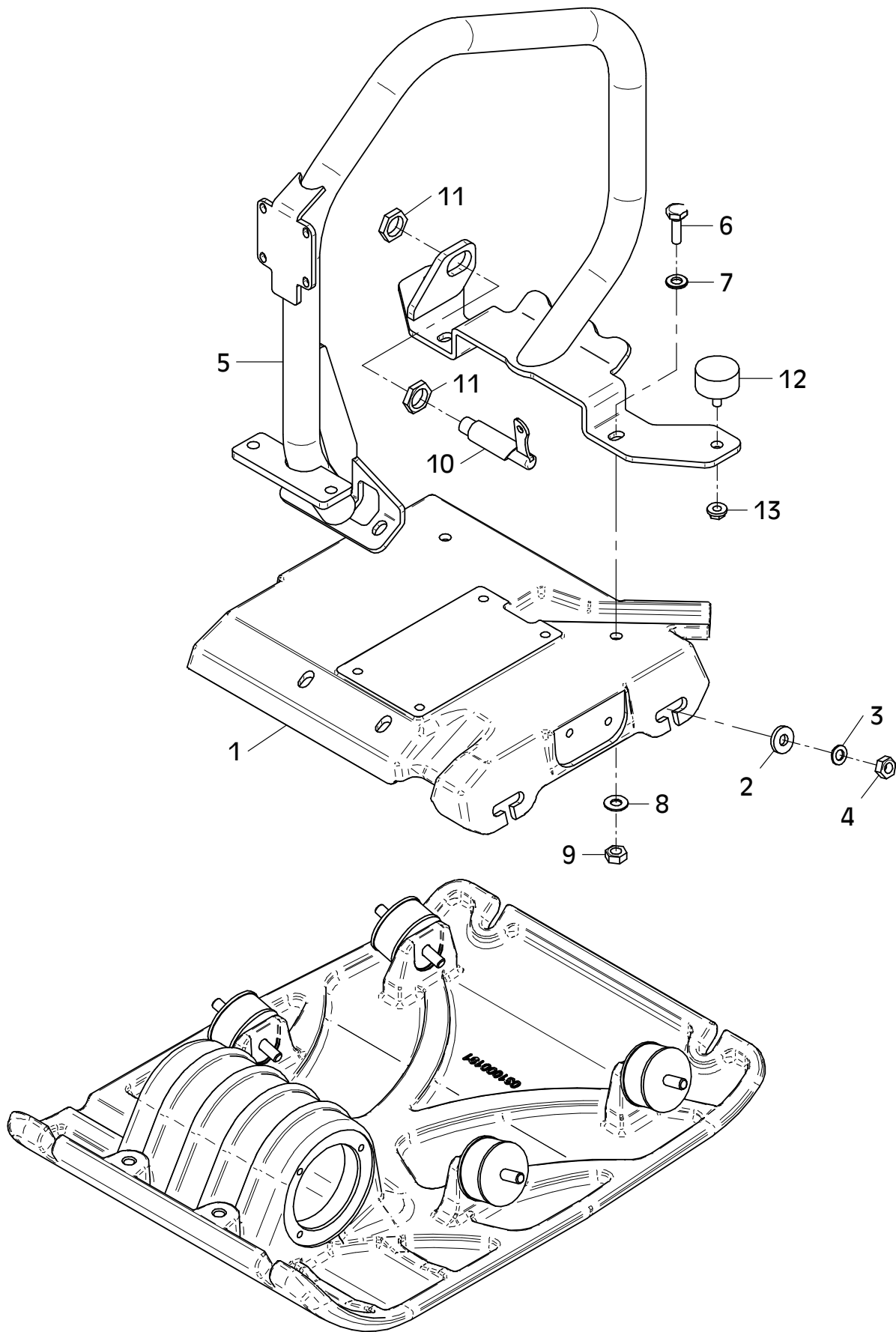

E 3590-0115

## E 3587-0115

Position Ref.No. Repère Posizione Posicion	Menge Quantity Quantité Quantita Cantidad	Teile-Nr. Part-No. No. Référence Nr. d'Ordine No. Referenzia	Hinweis Hints Indications Indicazione Indicaciones	Position Ref. No. Repère Posizione Posicion	Menge Quantity Quantité Quantita Cantidad	Teile-Nr. Part-No. No. Référence Nr. d'Ordine No. Referenzia	Hinweis Hints Indications Indicazione Indicaciones
1	1	21000901					
2	4	25040028	DIN931-M8x45				
3	4	20025122					
4	4	25049026	DIN7349-8,4				
5	4	20029024					
6	4	25031003	DIN934-M8				
7	1	30047446					
8	1	10016088					
9	1	10005238					
10	1	11001801					
11	4	25047062	DIN7991-5/16"-24UNF				
12	4	25005003	DIN6798-V8,4				
13	1	21000501					
14	1	25043005	DIN933-5/16"				
15	1	20029021	SKB 8				
16	1	21000634					
17	1	11000714					
18	4	21000586	DIN7964-M8x50				
19	4	20029003	VSK 8				
20	4	25048002	DIN125-A8,4				

# Robin

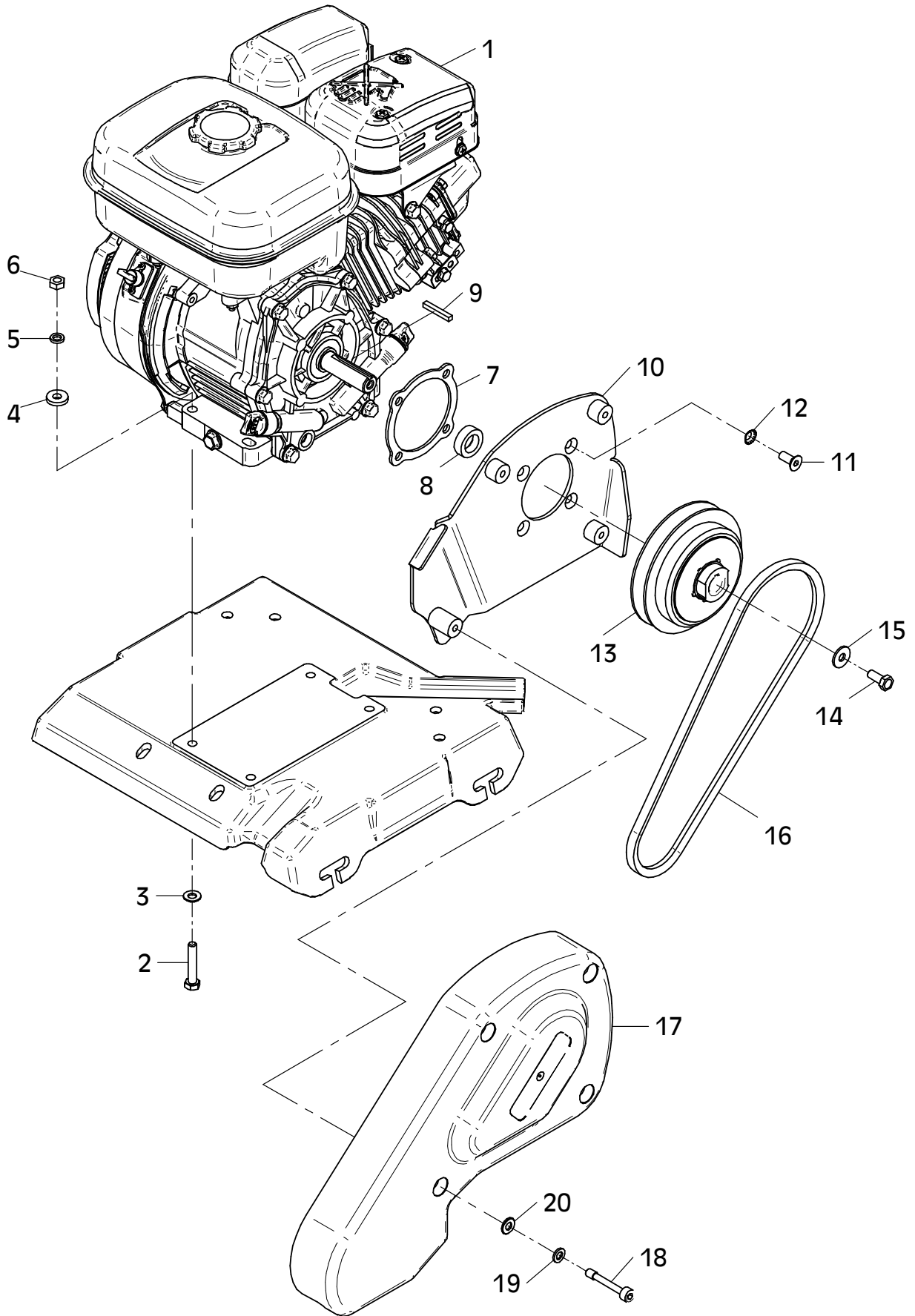

E 3587-0115

## E 3588-0115

Position Ref.No. Repère Posizione Posicion	Menge Quantity Quantité Quantita Cantidad	Teile-Nr. Part-No. No. Référence Nr. d'Ordine No. Referenzia	Hinweis Hints Indications Indicazione Indicaciones	Position Ref. No. Repère Posizione Posicion	Menge Quantity Quantité Quantita Cantidad	Teile-Nr. Part-No. No. Référence Nr. d'Ordine No. Referenzia	Hinweis Hints Indications Indicazione Indicaciones
1	1	21000608					
2	4	25040028	DIN931-M8x45				
3	4	20025122					
4	4	25049026	DIN7349-8,4				
5	4	20029024					
6	4	25031003	DIN934-M8				
7	1	30047446					
8	1	10016088					
9	1	10005238					
10	1	11001801					
11	4	25047062	DIN7991-5/16"-24UNF				
12	4	25005003	DIN6798-V8,4				
13	1	21000501					
14	1	25043005	DIN933-5/16"				
15	1	20029021	SKB 8				
16	1	21000634					
17	1	11000714					
18	4	21000586	DIN7964-M8x50				
19	4	20029003	VSK 8				
20	4	25048002	DIN125-A8,4				
21	1	21000610					
22	2	20026389					

Honda

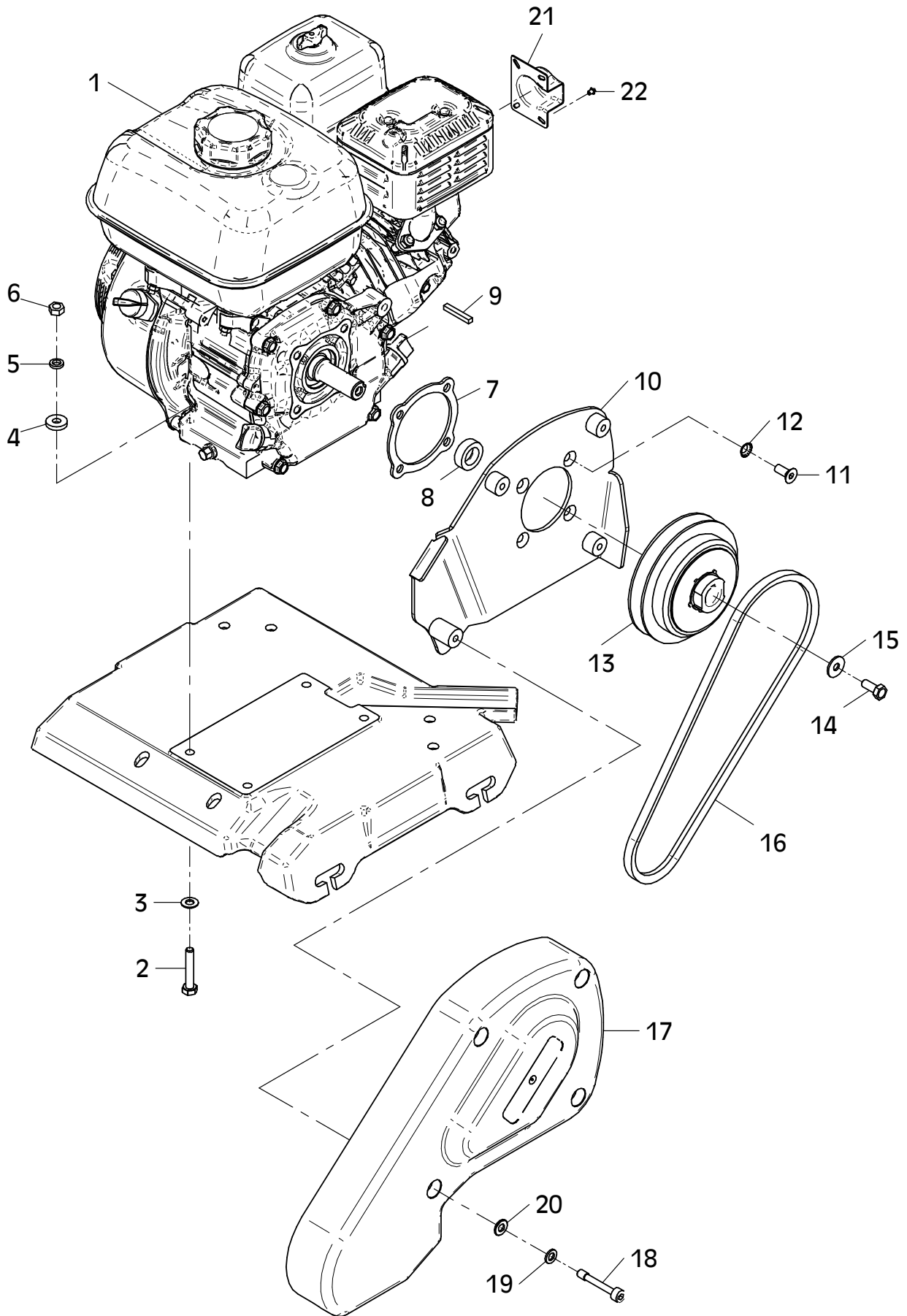

E 3588-0115

## E 3351-0310

Position Ref.No. Repère Posizione Posicion	Menge Quantity Quantité Quantita Cantidad	Teile-Nr. Part-No. No. Référence Nr. d'Ordine No. Referenzia	Hinweis Hints Indications Indicazione Indicaciones	Position Ref. No. Repère Posizione Posicion	Menge Quantity Quantité Quantita Cantidad	Teile-Nr. Part-No. No. Référence Nr. d'Ordine No. Referenzia	Hinweis Hints Indications Indicazione Indicaciones
1	1	21000501					
2	2	20002285					
3	2	21000594					
4	2	20002223					

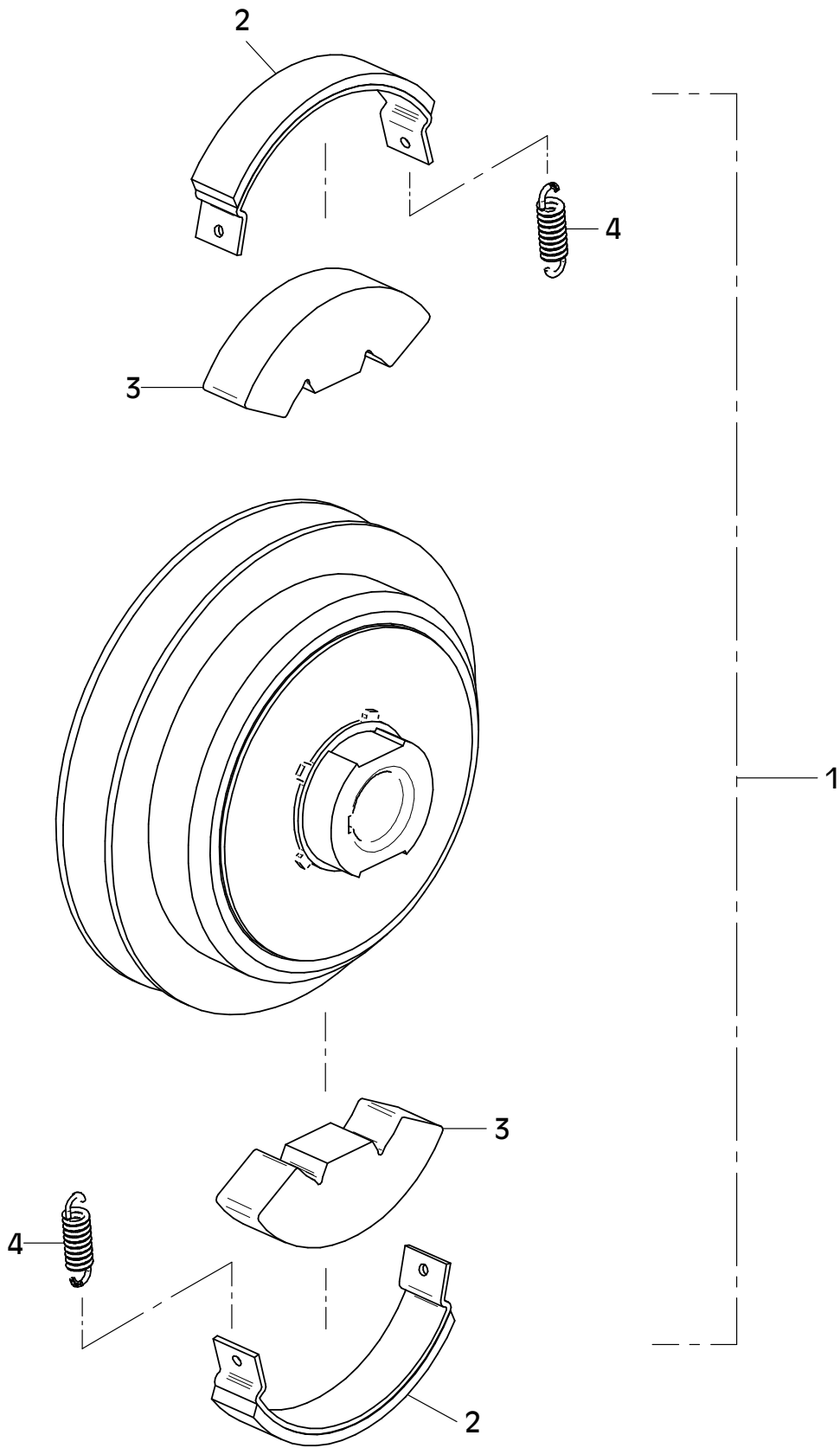

E 3351-0310

## E 3345-1116

Position Ref.No. Repère Posizione Posicion	Menge Quantity Quantité Quantita Cantidad	Teile-Nr. Part-No. No. Référence Nr. d'Ordine No. Referenzia	Hinweis Hints Indications Indicazione Indicaciones	Position Ref. No. Repère Posizione Posicion	Menge Quantity Quantité Quantita Cantidad	Teile-Nr. Part-No. No. Référence Nr. d'Ordine No. Referenzia	Hinweis Hints Indications Indicazione Indicaciones
1	1	11000751					
2	2	20025015					
3	1	25040012	DIN931-M10x55				
4	2	20029001	VSK 10				
5	2	25049013	DIN440-R11,5				
6	2	25031028	DIN1587-M10				
7	2	11000790					
8	1	11000754					
9	7	25044110	DIN912-M6x40				
10	7	25031012	DIN985-M6				
11	2	11001880					
12							
13	2	20029003	VSK 8				
14	2	25038009	DIN933-M8x30				
15	1	21000661					
16	1	25031024	DIN936-M10				
17	1	25048003	DIN125-A10,5				
18	2	10015958					



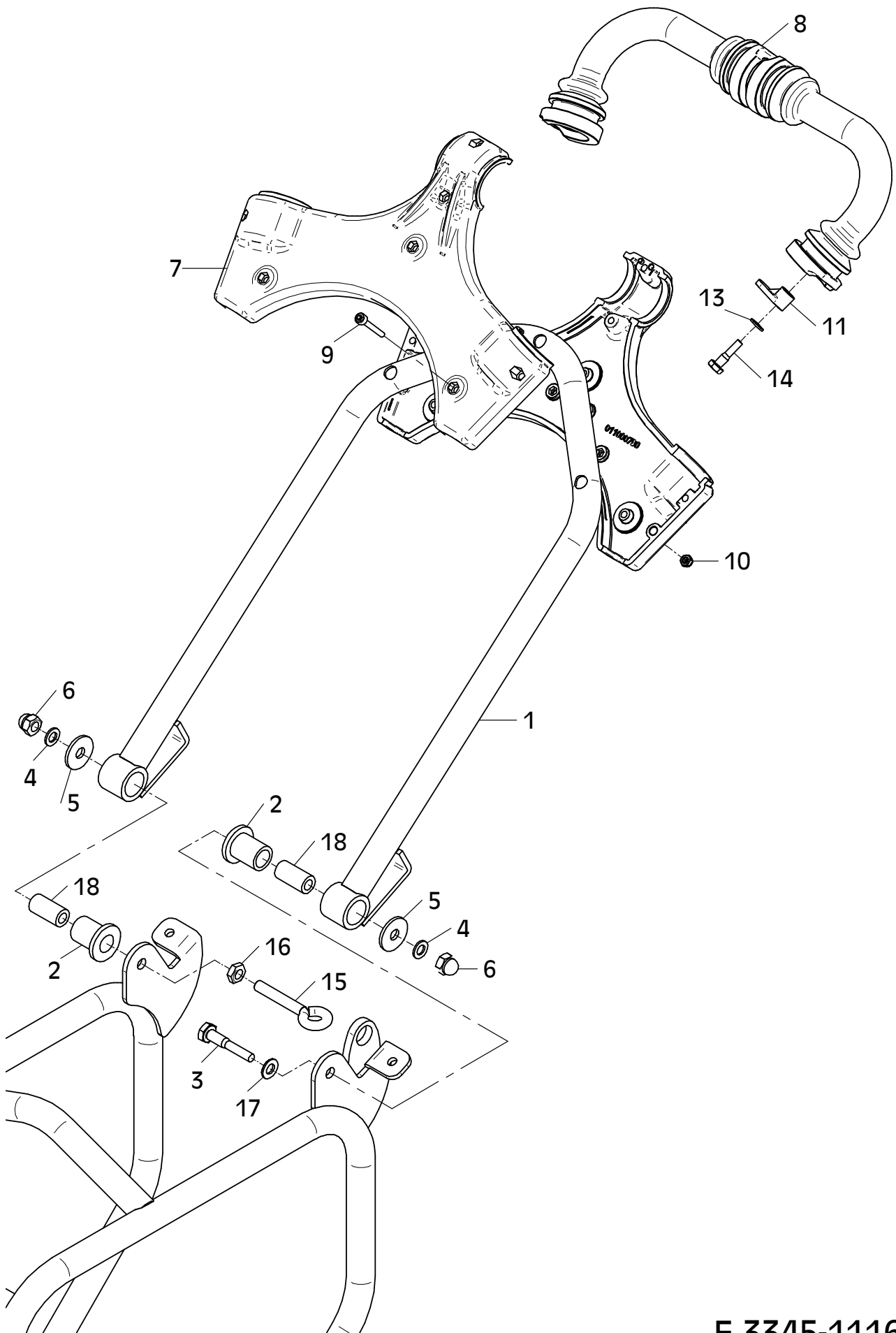

E 3345-1116

## E 3409-1210

Position Ref.No. Repère Posizione Posicion	Menge Quantity Quantité Quantita Cantidad	Teile-Nr. Part-No. No. Référence Nr. d'Ordine No. Referenzia	Hinweis Hints Indications Indicazione Indicaciones	Position Ref. No. Repère Posizione Posicion	Menge Quantity Quantité Quantita Cantidad	Teile-Nr. Part-No. No. Référence Nr. d'Ordine No. Referenzia	Hinweis Hints Indications Indicazione Indicaciones
1	2	25047016	DIN7991-M5x16				
2	2	25031023	DIN985-M5				
3	2	21000682					
10	1	21000582	<b>Honda</b>				
11	1	20026383					
12	1	21000335					
20	1	21000582	<b>Robin</b>				
21	1	25031002	DIN934-M6				
22	1	21000239					

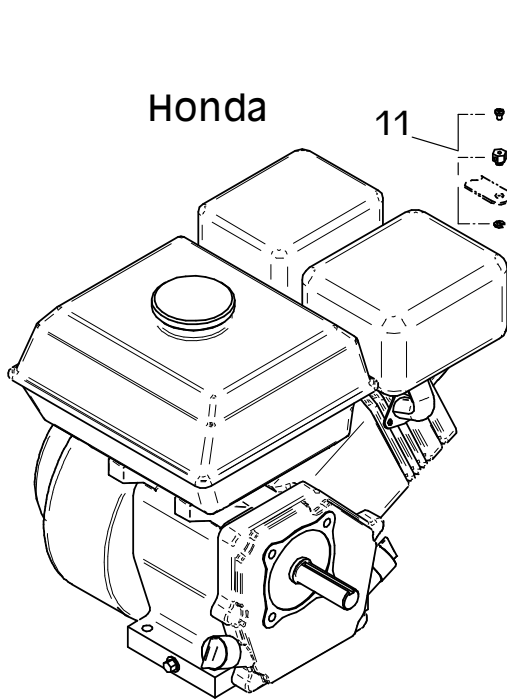
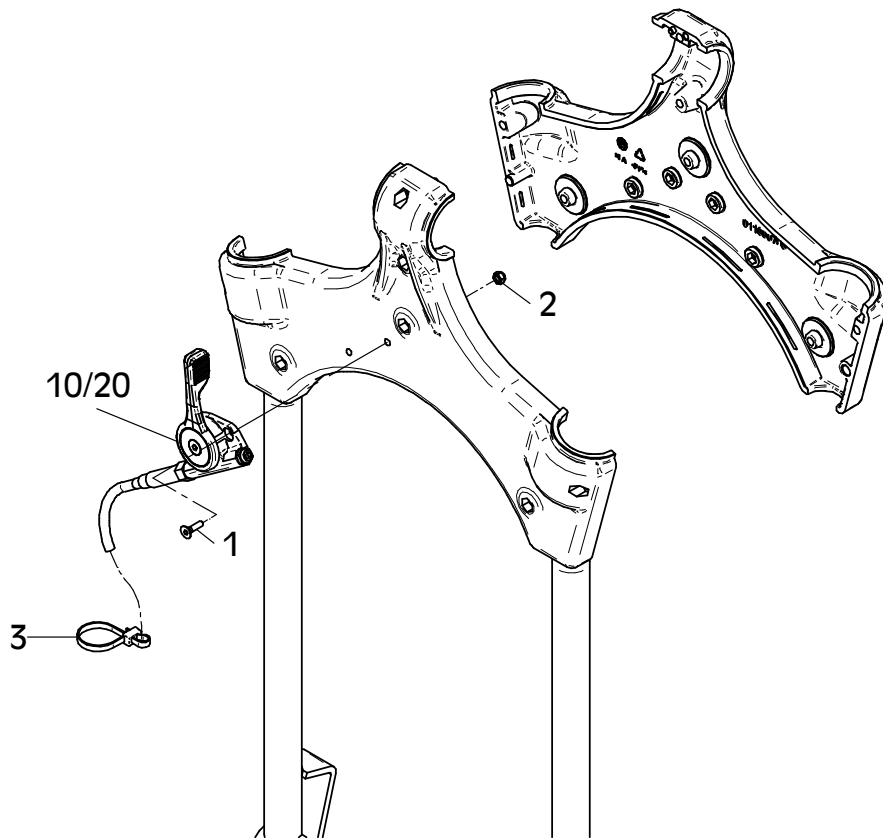

Honda

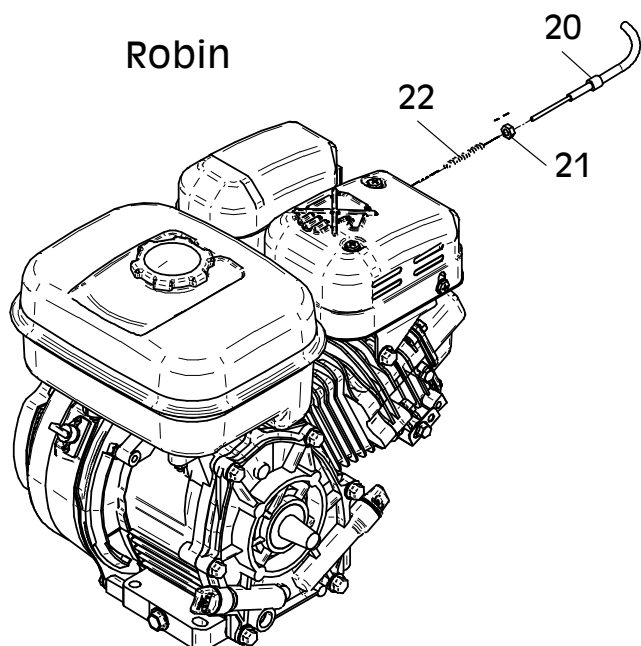
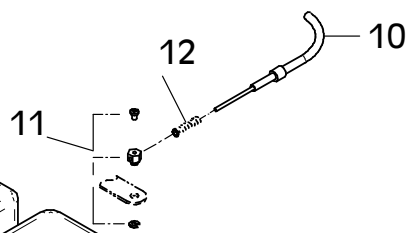

Robin

E 3409-1210

## E 3591-1016

Position Ref.No. Repère Posizione Posicion	Menge Quantity Quantité Quantita Cantidad	Teile-Nr. Part-No. No. Référence Nr. d'Ordine No. Referenzia	Hinweis Hints Indications Indicazione Indicaciones	Position Ref. No. Repère Posizione Posicion	Menge Quantity Quantité Quantita Cantidad	Teile-Nr. Part-No. No. Référence Nr. d'Ordine No. Referenzia	Hinweis Hints Indications Indicazione Indicaciones
1	1	11001803					
2	2	20025015					
3	2	10015958					
4	2	25040012	DIN931-M10x55				
5	2	20029001	VSK 10				
6	2	25049013	DIN440-R11,5				
7	2	25038022	DIN933-M12x40				
8	2	25031005	DIN934-M12				

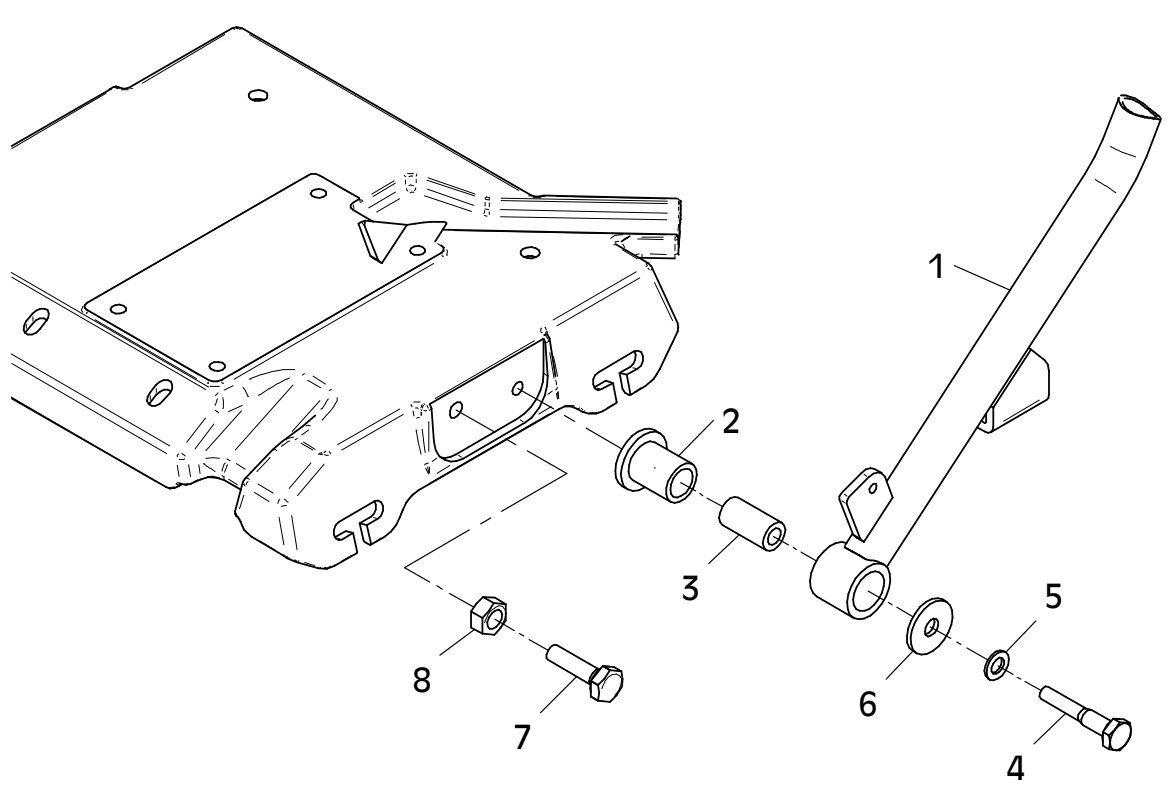
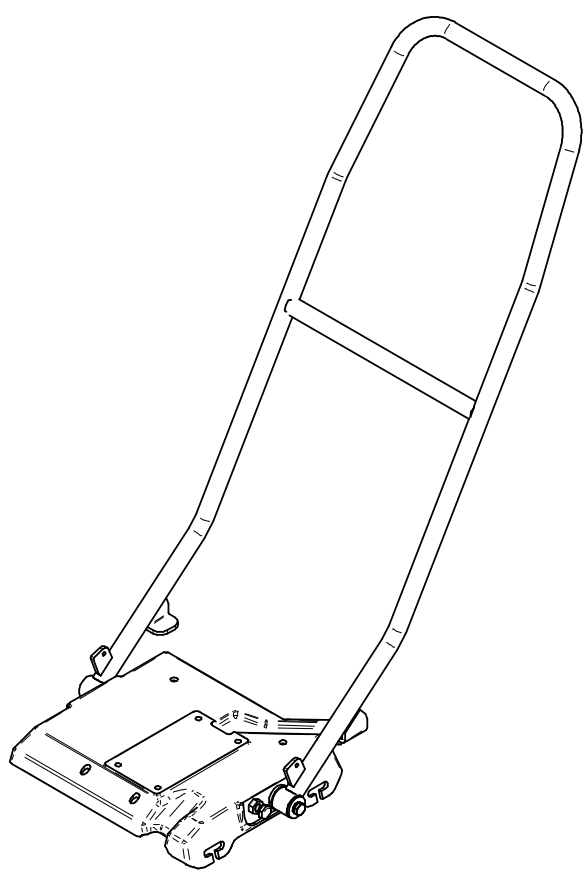

E 3591-1016

## E 3589-0916

Position Ref.No. Repère Posizione Posicion	Menge Quantity Quantité Quantita Cantidad	Teile-Nr. Part-No. No. Référence Nr. d'Ordine No. Referenzia	Hinweis Hints Indications Indicazione Indicaciones	Position Ref. No. Repère Posizione Posicion	Menge Quantity Quantité Quantita Cantidad	Teile-Nr. Part-No. No. Référence Nr. d'Ordine No. Referenzia	Hinweis Hints Indications Indicazione Indicaciones
1	1	21000481					
2	1	20025719					
3	4	25038002	DIN933-M6x16				
4	4	20029007	VSK 6				
5	4	25048001	DIN125-A6,4				
6	1	11001311					
7	1	11001598					
8	2	25030002	DIN908-M14x1,5				
9	1	11001597					
10	2	11001063					
11	1	21000492	DIN7991-M6x35				
12	1	25005002	DIN6798-V6,4				
13	1	21000849	0,3 m				
14	2	20007054					

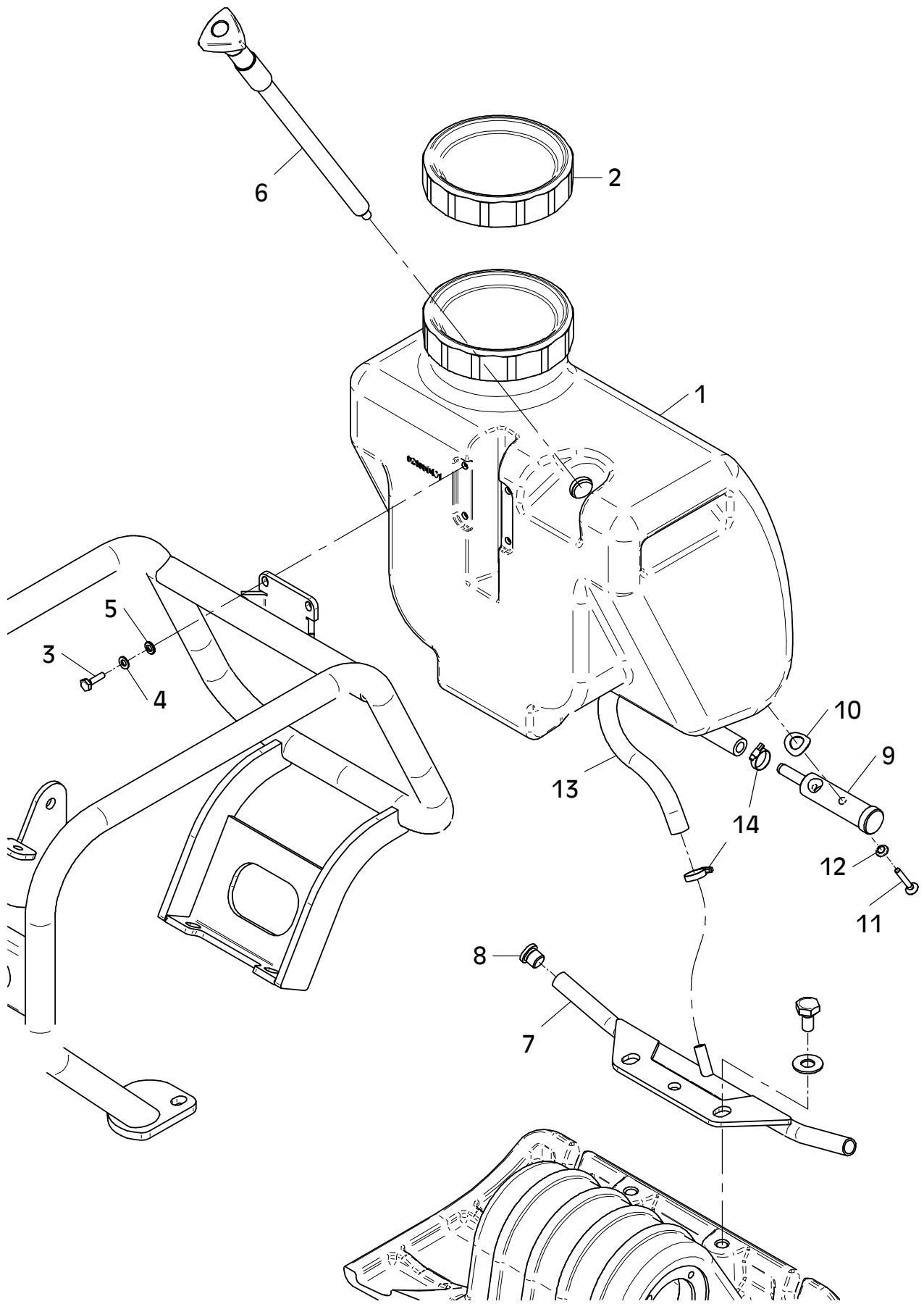

E 3589-0916

## E 3592-0916

Position Ref.No. Repère Posizione Posicion	Menge Quantity Quantité Quantita Cantidad	Teile-Nr. Part-No. No. Référence Nr. d'Ordine No. Referenzia	Hinweis Hints Indications Indicazione Indicaciones	Position Ref. No. Repère Posizione Posicion	Menge Quantity Quantité Quantita Cantidad	Teile-Nr. Part-No. No. Référence Nr. d'Ordine No. Referenzia	Hinweis Hints Indications Indicazione Indicaciones
1	1	21000481					
2	1	20025719					
3	4	25038002	DIN933-M6x16				
4	4	20029007	VSK 6				
5	4	25048001	DIN125-A6,4				
6	1	11001311					
7	1	11001598					
8	2	25030002	DIN908-M14x1,5				
9	1	11001597					
10	2	11001063					
11	1	21000492	DIN7991-M6x35				
12	1	25005002	DIN6798-V6,4				
13	1	21000849	0,3 m				
14	2	20007054					
15							
16							
17							
18	1	11001806					
19	2	25038015	DIN933-M10x30				
20	2	25048003	DIN125-A10,5				
21	2	20029001	VSK 10				
22	2	25031004	DIN934-M10				



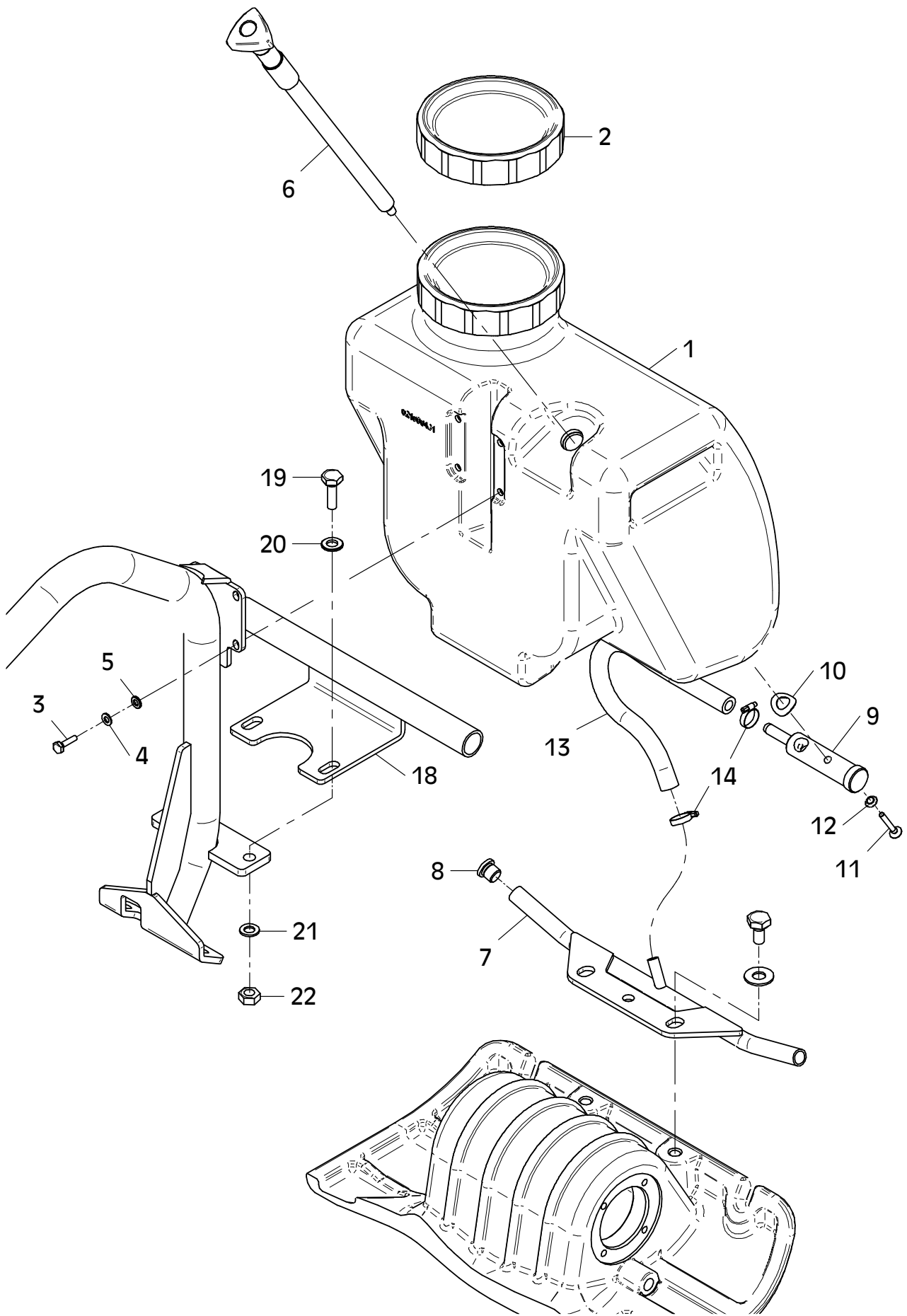

E 3592-0916

## E 3593-0115

Position Ref.No. Repère Posizione Posicion	Menge Quantity Quantité Quantita Cantidad	Teile-Nr. Part-No. No. Référence Nr. d'Ordine No. Referenzia	Hinweis Hints Indications Indicazione Indicaciones	Position Ref. No. Repère Posizione Posicion	Menge Quantity Quantité Quantita Cantidad	Teile-Nr. Part-No. No. Référence Nr. d'Ordine No. Referenzia	Hinweis Hints Indications Indicazione Indicaciones
1	1	11000762					
2	2	21000645					
3	2	21000869					
4	2	20008088					
5	1	11000768					
6	2	21000497					
7	1	11000769					
8	1	21000670	DIN931-M10x150				
9	1	25048003	DIN125-A10,5				
10	2	25038014	DIN933-M10x25				
11	2	20029001	VSK 10				
12	1	11001802					
13	1	21000491					
14	1	11000767					
15	1	25040011	DIN931-M10x50				
16	2	25048003	DIN125-A10,5				
17	1	20029001	VSK 10				
18	1	25031004	DIN934-M10				
19	1	20029001	VSK 10				
20	1	25031004	DIN934-M10				

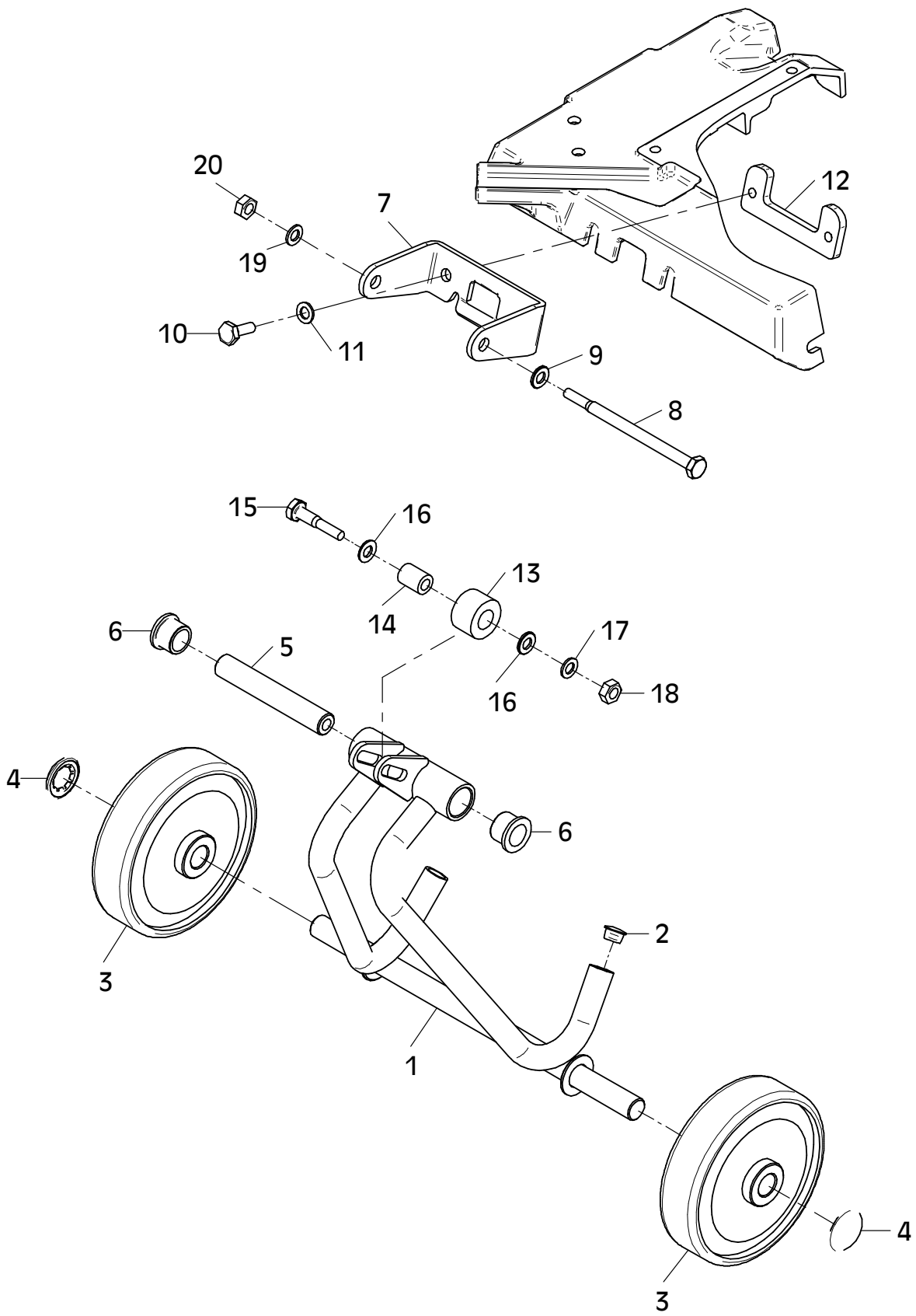

E 3593-0115

## E 3356-0512

Position Ref.No. Repère Posizione Posicion	Menge Quantity Quantité Quantita Cantidad	Teile-Nr. Part-No. No. Référence Nr. d'Ordine No. Referenzia	Hinweis Hints Indications Indicazione Indicaciones	Position Ref. No. Repère Posizione Posicion	Menge Quantity Quantité Quantita Cantidad	Teile-Nr. Part-No. No. Référence Nr. d'Ordine No. Referenzia	Hinweis Hints Indications Indicazione Indicaciones
1	1	11000773					
2	1	11000793					
3	2	25040012	DIN931-M10x55				
4	2	25049013	DIN440-R11,5				
5	2	25031014	DIN985-M10				
6	2	11000987					
7	2	11000336					
8	2	25047015	DIN7991-M10x20				

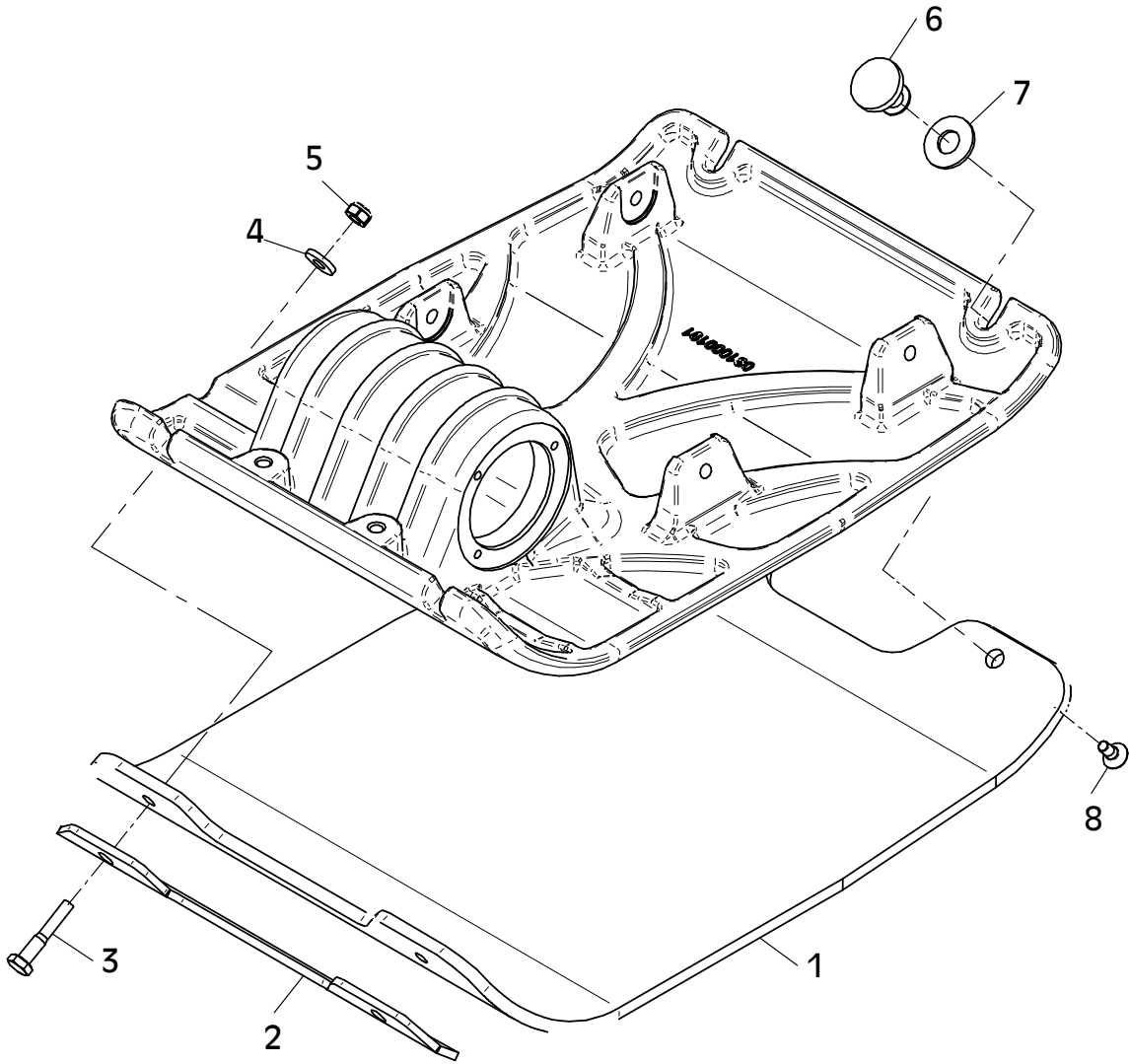

E 3356-0512

## E 3660-0815

Position Ref.No. Repère Posizione Posicion	Menge Quantity Quantité Quantita Cantidad	Teile-Nr. Part-No. No. Référence Nr. d'Ordine No. Referenzia	Hinweis Hints Indications Indicazione Indicaciones	Position Ref. No. Repère Posizione Posicion	Menge Quantity Quantité Quantita Cantidad	Teile-Nr. Part-No. No. Référence Nr. d'Ordine No. Referenzia	Hinweis Hints Indications Indicazione Indicaciones
1	1	20019006					
2	1	20019007					
3	1	21000047					
4	1	20019376					
5	1	20019097					
6	1	20019281					
7	1	20019104					
8	1	21000474					
9	1	20019397					

**Alle Schraubenverbindungen ständig auf festen Sitz überwachen!**  
-Besonders nach dem ersten Einsatz-

**Continuously check all screwed connections for firm seating**  
-particularly after initial employment-

**Controler continuellement tous les raccords a vis pour un siege ferme**  
-particulierement apres l'emploi initial-

1

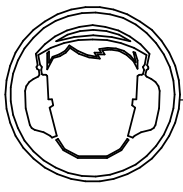

2

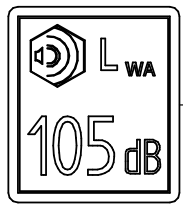

3

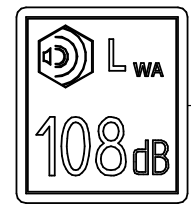

4



5

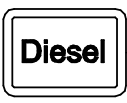

6



7

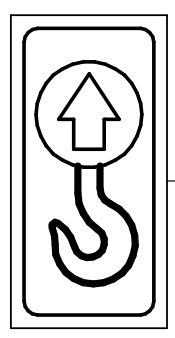

8

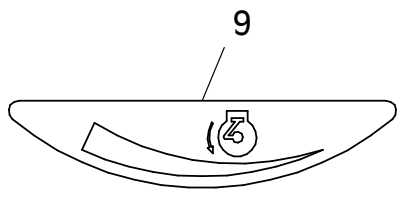

9

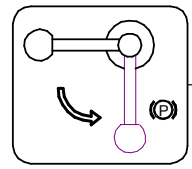

10









Wenn Sie Fragen, Anregungen, Probleme, usw. haben, wenden Sie sich bitte an eine der unten genannten Adressen:

For problems, questions and further information refer to one of the following addresses:

Si des questions, des suggestions, des problèmes ... survenaient, veuillez vous adresser a l'une des adresses - ci dessous

<p>in Deutschland</p> <p>in Germany</p> <p>Pour l' Allemagne</p>	<p>WEBER Maschinentechnik GmbH Im Boden 5-8 , 10 57334 Bad Laasphe – Rückershausen</p>	<p>Telefon Telefax</p> <p>E-Mail</p>	<p>+ 49 (0) 2754 - 398-0 + 49 (0) 2754 - 398101-Zentrale switchboard Central + 49 (0) 2754 - 398102-Ersatzteil-Direktlinie spare parts-directlinie Ligne direct pièces détachées</p> <p><a href="mailto:g.voelkel@webermt.de">g.voelkel@webermt.de</a></p>
<p>in Frankreich</p> <p>in France</p> <p>Pour la France</p>	<p>WEBER Technologie SARL 26' rue d' Arsonval 69680 Chassieu</p>	<p>Telefon Telefax</p> <p>E-Mail</p>	<p>+ 33 (0) 472 - 791020 + 33 (0) 472 - 791021</p> <p><a href="mailto:france@webermt.com">france@webermt.com</a></p>
<p>in Polen</p> <p>in Poland</p> <p>Pour la Pologne</p>	<p>WEBER Maschinentechnik Sp. zo.o. Ul. Grodziska 7 05-830 Stara Wies</p>	<p>Telefon Telefax</p> <p>E-Mail</p>	<p>+ 48 (0) 22 - 739 70 - 80 + 48 (0) 22 - 739 70 - 81 + 48 (0) 22 - 739 70 - 82</p> <p><a href="mailto:info@webermt.com.pl">info@webermt.com.pl</a></p>
<p>in Tschechien</p> <p>in Czechia</p> <p>Pour la Tchéquie</p>	<p>WEBER MT s.r.o. V Piskovně 2054 278 01 Kralupy nad Vitavou</p>	<p>Telefon</p> <p>E-Mail</p>	<p>+ 42 (0) 776 222 216 + 42 (0) 776 222 261</p> <p><a href="mailto:info@webermt.cz">info@webermt.cz</a></p>
<p>in USA und Kanada</p> <p>in USA and Canada</p> <p>Pour les Etats Unis Et le Canada</p>	<p>WEBER MT, Inc. 45 Dowd Road Bangor, ME 04401</p>	<p>Telefon Telefax</p> <p>E-Mail</p>	<p>+ 1(207) - 947 - 4990 + 1(207) - 947 - 5452</p> <p><a href="mailto:sales@webermt.com">sales@webermt.com</a> <a href="mailto:service@webermt.com">service@webermt.com</a></p>
<p>in Süd – Amerika</p> <p>in South – America</p> <p>Pour l' Amérique du sud</p>	<p>WEBER Maschinentechnik do Brasil Rua João Werno Erhart, 4691 Bairro Rinçãõ 93310 – 405 Novo Hamburgo / RS Brasilien</p>	<p>Telefon Telefax</p> <p>E-Mail</p>	<p>+ 55 (0) 51- 587 3044 + 55 (0) 51- 587 2271</p> <p><a href="mailto:webermt@webermt.com.br">webermt@webermt.com.br</a></p>

