



# PARTS DRAWING



**Delta 110v Battery  
Back Up LED Uplight**

**Product Code:  
DL36BB**



Serial Number Range:

From:

To:

Year Of Manufacture:

**\*Please note, when ordering online via our website if the part number is not recognised,  
please Email [spares@hscgroupuk.co.uk](mailto:spares@hscgroupuk.co.uk) or Telephone 0115 946 1988**

**KEEP THIS BOOKLET FOR FUTURE REFERENCE**

Nottingham: 0115 946 1988 • London: 0208 830 3333 ✉ Nottingham: [sales@hscgroupuk.co.uk](mailto:sales@hscgroupuk.co.uk) • London: [sean@hscgroupuk.co.uk](mailto:sean@hscgroupuk.co.uk) 🌐 [www.hscgroupuk.co.uk](http://www.hscgroupuk.co.uk)

The Hire Supply Company Terms & Conditions Apply At All Time E&OE

No.	Drawing / PN. No.	Description
1-1	DL36TC	Cap -Top Cover
1-2	N/A	Self Tapping 2.5 x 10mm - Pan Pozi self coloured screws
1-3	DL36ULH	Upper lamp holder for LED fixing bar
1-4	N/A	Waterproof ring gasket for LED fixing bar
1-5	N/A	Waterproof O-ring gasket - diffuser seal
1-6	N/A	Diffuser - Opal
1-7	N/A	Heat sink - LED PCBA extrusion
1-8	N/A	LED Linear Strip board - 2-3W per board
1-9	N/A	LED Ring PCB connector
1-10	N/A	Diffusor compression ring
1-11	N/A	Waterproof o-ring gasket -diffusor compressor ring seal
1-12	LED36WULB	Top Cover base moulding
1-13	N/A	Self Tapping M4 x 16mm - Pan Pozi Plastech screws - Black
1-14	N/A	Grommet- Cable entry bulkhead grommet
1-15	DL36LLH	Lower lamp holder for LED fixing bar
1-16	N/A	Self Tapping M3 x 6mm - Pan Pozi Plastech screws - Diffusor retention screw

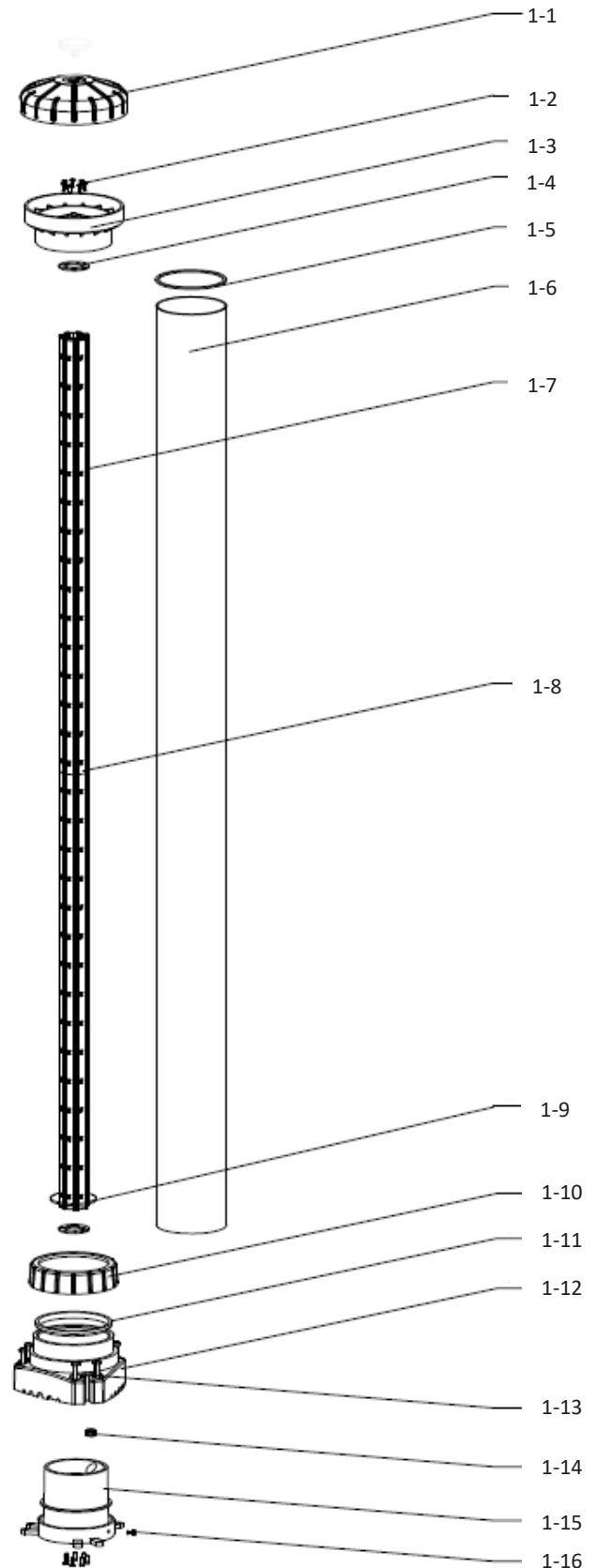

Part No: **DL36LIGHTHEAD**

Description: Delta Light 36W LED  
Light head – Compatible with all  
variants of Delta Lights

Part No: **DL36BBBASE**

**DL36BB (Complete unit)**

Description: Delta Light 36W Base  
with Battery Back-up module

– 110V input voltage

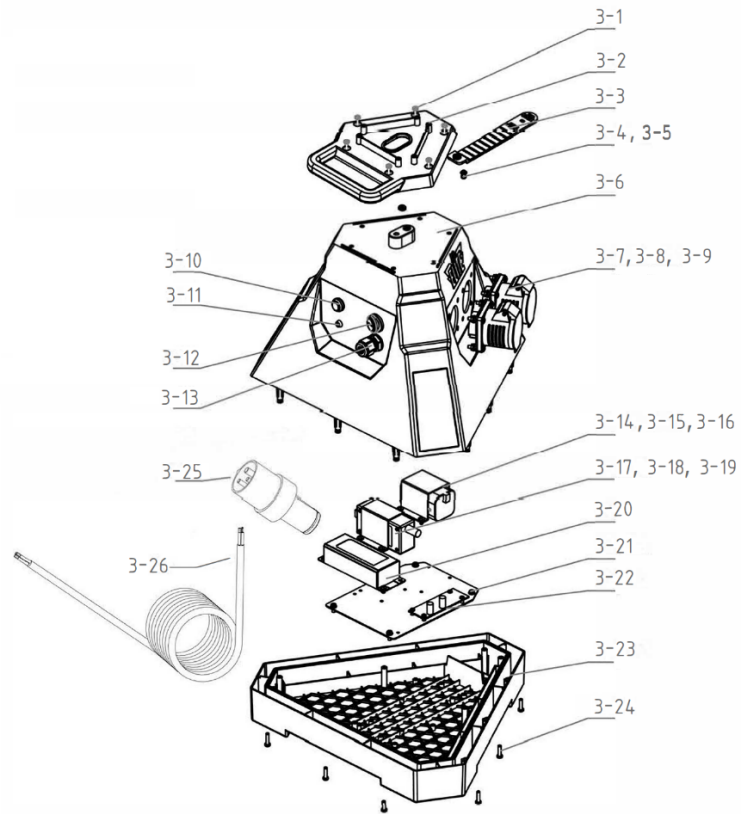

No.	Drawing / PN. No.	Description	No.	Drawing / PN. No.	Description
3-1	N/A	Self Tapping M4 x 16mm - Pan Pozi Plastech screws - Base handle plate screws	3-14	DL36BBUB	Battery – 7.4V 5.2Ah
3-2	DL36BHPG	Base handle plate - Green	3-15	DL36BBUBRP	Battery retaining plate
3-3	DL36CS	Cable Management Strap	3-16	N/A	Battery retaining plate screws – M4 x 6mm
3-4	N/A	Self Tapping Screw M4 x 8mm - Cable Management Strap	3-17	DL36BBUC	Battery Charger – 9V dc 1.0A
3-5	N/A	M4 Washer - Cable Management Strap	3-18	DL36BBUBCRP	Battery Charger retaining plate
3-6	DL36BH	Base Housing	3-19	N/A	Battery Charger retaining plate screws - M4 x 6mm
3-7	16APS110	16A 110V Panel Socket incl gasket - BS60309 - Standard hole centres	3-20	DL36D	36 watt Constant current LED Driver
3-8	N/A	Machine Screws - M4 x 20mm BZP	3-21	N/A	Electronic component mounting plate
3-9	N/A	Nyloc Nut - M4	3-22	DL36BBUAPSM	Auto Power switching PCBA module
3-10	DL36BBUPSS	Power Select Switch	3-23	DL36B	Base Footplate
3-11	DL36BBUPCSI	Battery Charge Status Indicator	3-24	N/A	Base Footplate fixing screws - Self Tapping M4 x 16mm - Pan Pozi Plastech screws -
3-12	DL36MS	On / Off Switch	3-25	16AP110	Mains In Plug
3-13	DL36BBUCCG	Cable compression gland - PG11	3-26	PTL1.53C	Mains In Cable - 3C 1.5mm H07 - RNF



## Recycling



**ENVIRONMENTAL PROTECTION:** Please recycle any unwanted materials as opposed to disposing them as general waste. It is recommended the original is retained and used to store the product when not in use for prolonged periods of time. If this is not applicable ensure the materials are sorted and recycled in accordance with local regulations.



**SPECIFICATION CHANGE:** It is our policy to continually improve products to ensure these meet the rigours of the industry we serve. Therefore, as such we reserve the right to alter specifications, data, components & parts with-out prior notice.

**WARRANTY:** Please refer to the manufactures terms & conditions.

**IMPORTANT:** No liability will be accepted for the incorrect use of this product.

### KEEP THIS BOOKLET FOR FUTURE REFERENCE

📞 Nottingham: 0115 946 1988 • London: 0208 830 3333    ✉ Nottingham: [sales@hscgroupuk.co.uk](mailto:sales@hscgroupuk.co.uk) • London: [sean@hscgroupuk.co.uk](mailto:sean@hscgroupuk.co.uk)    🌐 [www.hscgroupuk.co.uk](http://www.hscgroupuk.co.uk)

The Hire Supply Company Terms & Conditions Apply At All Time E&OE