



PARTS DRAWING

MCE MASTER
CLIMATE SOLUTIONS

**Master 15kw
3 Phase Fan Heater**

**Product Code:
B15415V**

Serial Number Range:

From: XXC3400001

To: 08C36005885

Year Of Manufacture: 2015



***Please note, when ordering online via our website if the part number is not recognised, please Email spares@hscgroupuk.co.uk or Telephone 0115 946 1988**

KEEP THIS BOOKLET FOR FUTURE REFERENCE

Nottingham: 0115 946 1988 • London: 0208 830 3333 ✉ Nottingham: sales@hscgroupuk.co.uk • London: sean@hscgroupuk.co.uk 🌐 www.hscgroupuk.co.uk

The Hire Supply Company Terms & Conditions Apply At All Time E&OE

MODEL B 15 EPB

UNIT 1

ILLUSTRATED PARTS BREAKDOWN

From Serial Number: XXC3400001

Until Serial Number: 08C36005885

Rev.-- May 2015

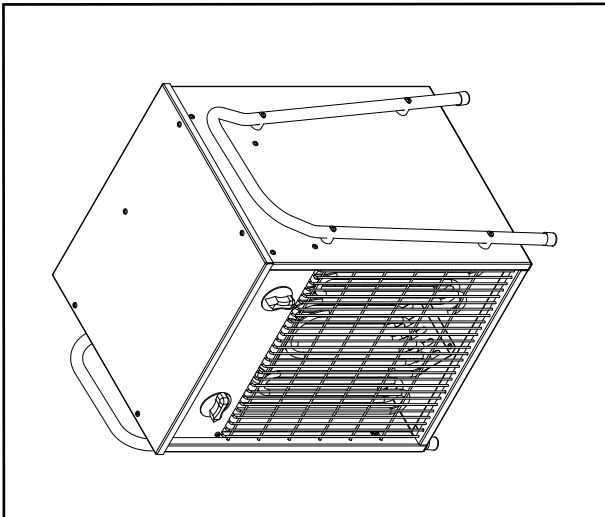
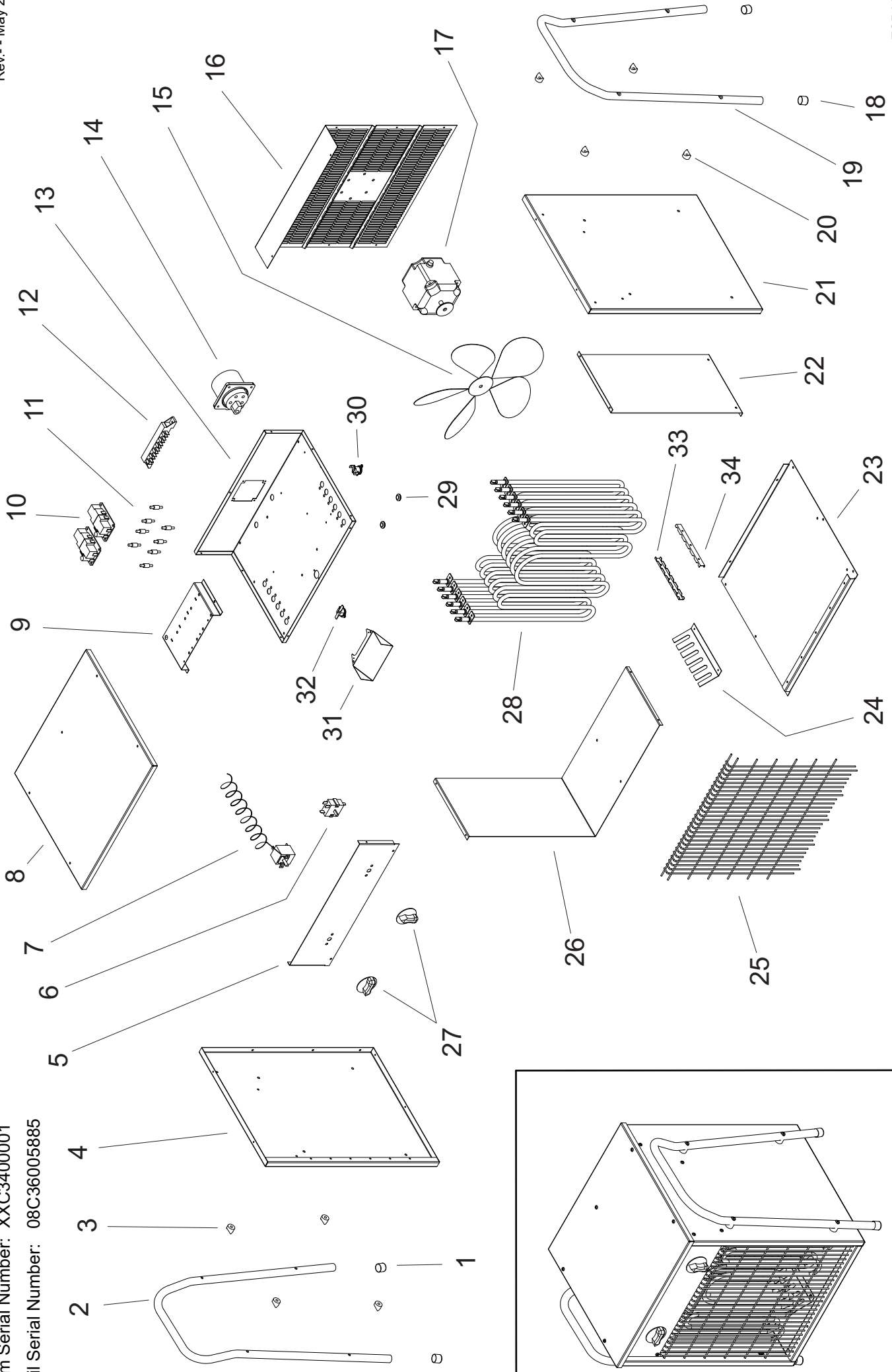

MODEL B 15EPB

UNIT 2

PARTS LIST

Pos.	Code N°	Description	Rev. - - June 2015
1	4510.623	HANDLE CAP	
2	4510.129	HANDLE	
3	4510.603	HANDLE SPACER	
4	4511.268	RIGHT PANEL	
5	4511.252	FRONTAL PANEL	
6	4510.401	SELECTOR	
7	4510.416	THERMOSTAT	
8	4511.270	UPPER PANEL	
9	4511.271	RELAY BRACKET	
10	4510.471	RELAY BOARD	
11	4517.613	BOARD SPACER	
12	4510.414	TERMINAL BOX	
13	4511.250	BASE	
14	4160.103	PANEL PLUG 5P	
15	4510.314	FAN	
16	4511.248	REAR PANEL	
17	4510.321	MOTOR	
18	4510.623	HANDLE CAP	
19	4510.129	HANDLE	
20	4510.603	HANDLE SPACER	
21	4511.269	LEFT PANEL	
22	4511.247	THERMAL SHIELD	
23	4511.272	LOWER PANEL	
24	4511.251	RESISTANCE BRACKET	
25	4511.274	FRONT GRILL	
26	4511.246	THERMAL L SHIELD	
27	4165.007	REGULATION HANDLE	
28	4510.374	RESISTANCE	
29	4511.621	WIRE PROTECTION	
30	4510.404	TEMPERATURE SENSOR	
31	4511.220	TEMPERATURE PROTECTION BRACKET	
32	4510.450	SAFETY THERMOSTAT	
33	4511.214	RIGHT RESISTANCE SUPPORT	
34	4511.245	LEFT RESISTANCE SUPPORT	



Recycling



ENVIRONMENTAL PROTECTION: Please recycle any unwanted materials as opposed to disposing them as general waste. It is recommended the original is retained and used to store the product when not in use for prolonged periods of time. If this is not applicable ensure the materials are sorted and recycled in accordance with local regulations.



SPECIFICATION CHANGE: It is our policy to continually improve products to ensure these meet the rigours of the industry we serve. Therefore, as such we reserve the right to alter specifications, data, components & parts with-out prior notice.

WARRANTY: Please refer to the manufactures terms & conditions.

IMPORTANT: No liability will be accepted for the incorrect use of this product.

KEEP THIS BOOKLET FOR FUTURE REFERENCE

📞 Nottingham: 0115 946 1988 • London: 0208 830 3333 ✉ Nottingham: sales@hscgroupuk.co.uk • London: sean@hscgroupuk.co.uk 🌐 www.hscgroupuk.co.uk

The Hire Supply Company Terms & Conditions Apply At All Time E&OE